

2A, 120V Trench Schottky Surface Mount Rectifier

FEATURES

- AEC-Q101 qualified
- Low power loss, high efficiency
- Ideal for automated placement
- High surge current capability
- Moisture sensitivity level: level 1, per J-STD-020
- RoHS compliant
- Halogen-free

APPLICATIONS

- Low voltage, high freq. inverter
- DC to DC converter
- Freewheeling diodes
- Reverse battery protection

MECHANICAL DATA

- Case: Micro SMA
- Molding compound meets UL 94V-0 flammability rating
- Terminal: Matte tin plated leads, solderable per J-STD-002
- Meet JESD 201 class 2 whisker test
- Polarity: Indicated by cathode band
- Weight: 0.006g (approximately)

KEY PARAMETERS		
PARAMETER	VALUE	UNIT
I_F	2	A
V_{RRM}	120	V
I_{FSM}	40	A
$T_{J\ MAX}$	175	°C
Package	Micro SMA	
Configuration	Single die	



Micro SMA



ABSOLUTE MAXIMUM RATINGS ($T_A = 25^\circ\text{C}$ unless otherwise noted)			
PARAMETER	SYMBOL	VALUE	UNIT
Repetitive peak reverse voltage	V_{RRM}	120	V
Reverse voltage, total rms value	$V_{R(RMS)}$	84	V
Forward current	I_F	2	A
Peak forward surge current, 8.3ms single half sine-wave superimposed on rated load	I_{FSM}	40	A
Junction temperature	T_J	- 55 to +175	°C
Storage temperature	T_{STG}	- 55 to +175	°C

THERMAL PERFORMANCE			
PARAMETER	SYMBOL	TYP	UNIT
Junction-to-lead thermal resistance	$R_{\theta JL}$	21	°C/W
Junction-to-ambient thermal resistance	$R_{\theta JA}$	82	°C/W
Junction-to-case thermal resistance	$R_{\theta JC}$	25	°C/W

Thermal Performance Note: Units mounted on PCB (5mm x 5mm Cu pad test board)

ELECTRICAL SPECIFICATIONS ($T_A = 25^\circ\text{C}$ unless otherwise noted)					
PARAMETER	CONDITIONS	SYMBOL	TYP	MAX	UNIT
Forward voltage ⁽¹⁾	$I_F = 1\text{A}, T_J = 25^\circ\text{C}$	V_F	0.72	-	V
	$I_F = 2\text{A}, T_J = 25^\circ\text{C}$		0.79	0.87	V
	$I_F = 1\text{A}, T_J = 125^\circ\text{C}$		0.58	-	V
	$I_F = 2\text{A}, T_J = 125^\circ\text{C}$		0.65	0.72	V
Reverse current @ rated V_R ⁽²⁾	$T_J = 25^\circ\text{C}$	I_R	-	2	μA
	$T_J = 125^\circ\text{C}$		-	1	mA
Junction capacitance	1MHz, $V_R = 4.0\text{V}$	C_J	57	-	pF

Notes:

1. Pulse test with PW = 0.3ms
2. Pulse test with PW = 30ms

ORDERING INFORMATION		
ORDERING CODE	PACKAGE	PACKING
TSU2H120H	Micro SMA	12,000 / Tape & Reel

CHARACTERISTICS CURVES

($T_A = 25^\circ\text{C}$ unless otherwise noted)

Fig.1 Forward Current Derating Curve

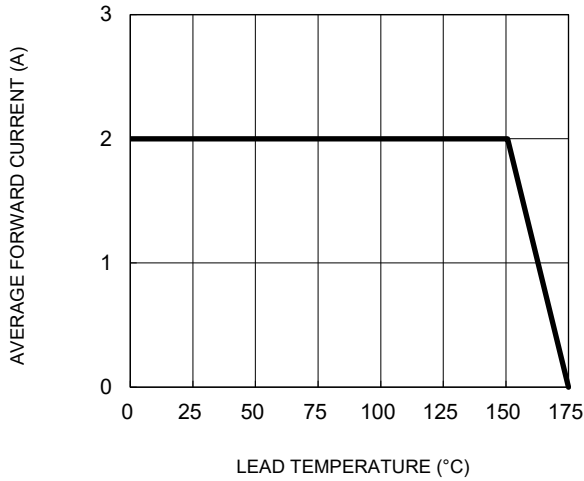

Fig.2 Typical Junction Capacitance

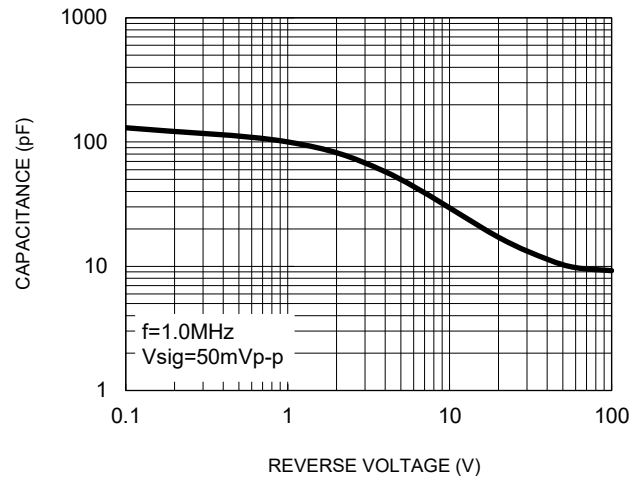

Fig.3 Typical Reverse Characteristics

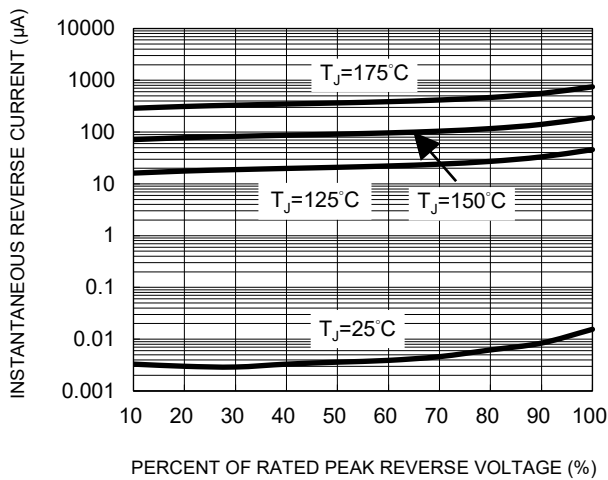

Fig.4 Typical Forward Characteristics

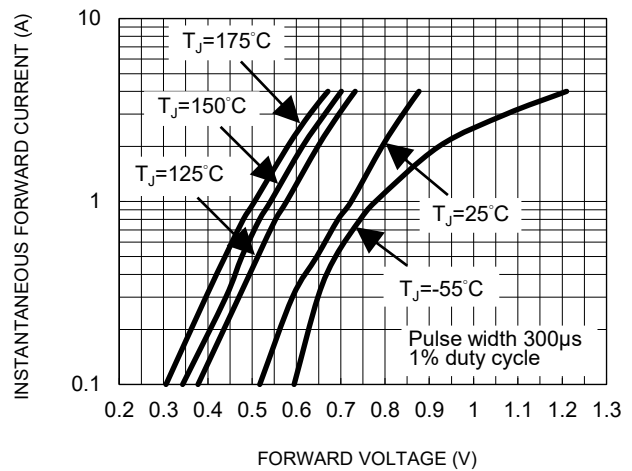
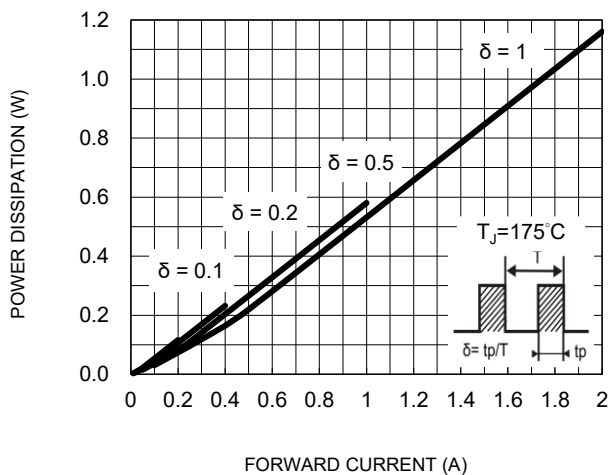

Fig.5 Typical Forward Power Dissipation vs. Forward Current



CHARACTERISTICS CURVES

(T_A = 25°C unless otherwise noted)

Fig.6 Typical Transient Thermal Characteristics

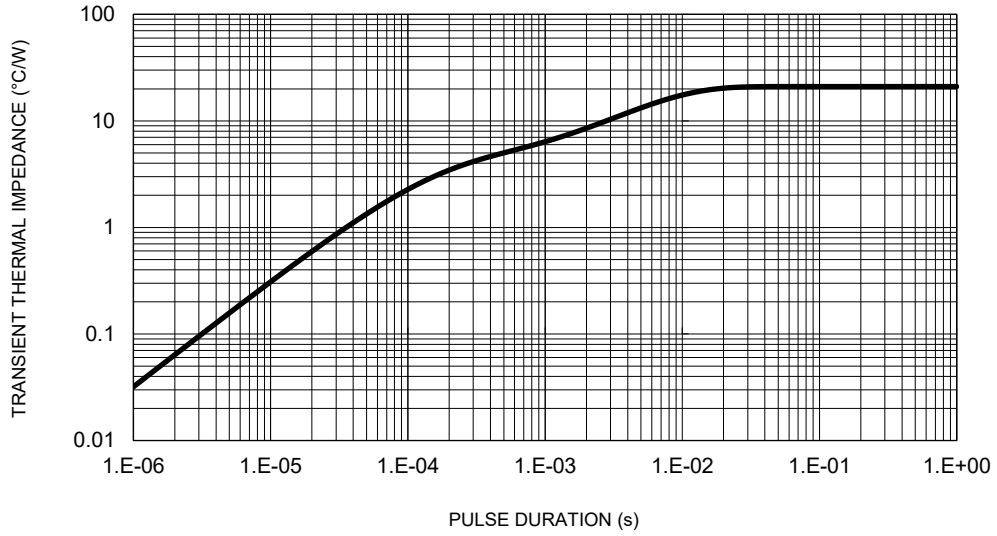

PACKAGE OUTLINE DIMENSIONS

Micro SMA

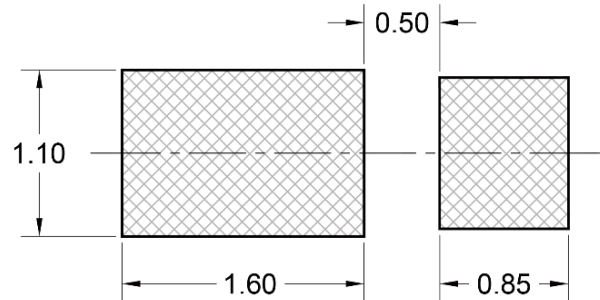
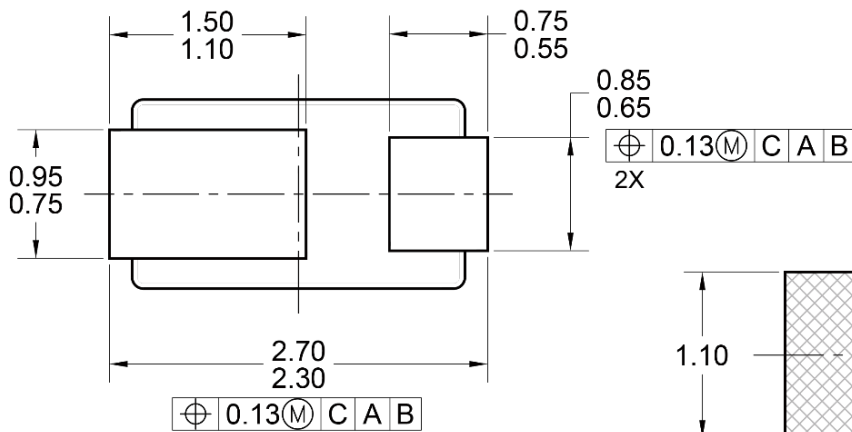
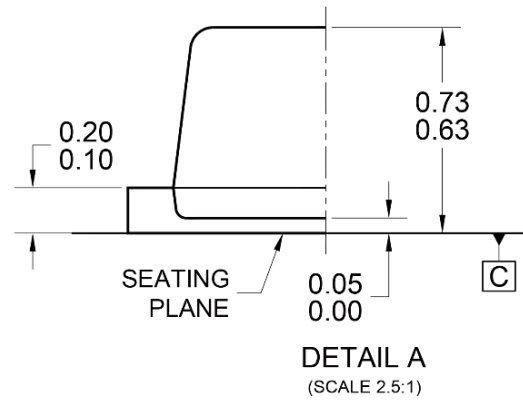
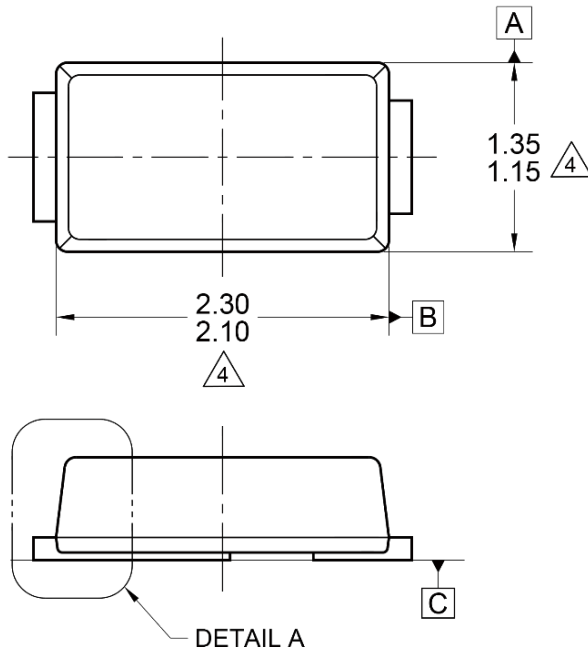

SUGGESTED PAD LAYOUT

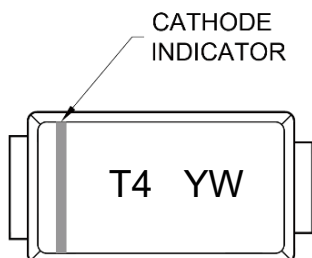

MARKING DIAGRAM

YW = Date code

NOTES: UNLESS OTHERWISE SPECIFIED

1. ALL DIMENSIONS ARE IN MILLIMETERS.
2. DIMENSIONING AND TOLERANCING PER ASME Y14.5M-2009.
3. PACKAGE OUTLINE REFERENCE: JEDEC DO-219, VARIATION AD, ISSUE C.
4. MOLDED PLASTIC BODY DIMENSIONS DO NOT INCLUDE MOLD FLASH.
5. DWG NO. REF: HQ2SD07-MSMA-070 REV A.

Notice

Specifications of the products displayed herein are subject to change without notice. TSC or anyone on its behalf assumes no responsibility or liability for any errors or inaccuracies.

Purchasers are solely responsible for the choice, selection, and use of TSC products and TSC assumes no liability for application assistance or the design of Purchasers' products.

Information contained herein is intended to provide a product description only. No license, express or implied, to any intellectual property rights is granted by this document. Except as provided in TSC's terms and conditions of sale for such products, TSC assumes no liability whatsoever, and disclaims any express or implied warranty, relating to sale and/or use of TSC products including liability or warranties relating to fitness for a particular purpose, merchantability, or infringement of any patent, copyright, or other intellectual property right.

The products shown herein are not designed for use in medical, life-saving, or life-sustaining applications. Customers using or selling these products for use in such applications do so at their own risk and agree to fully indemnify TSC for any damages resulting from such improper use or sale.