

## 20A, 120V Trench Schottky Surface Mount Rectifier

### FEATURES

- AEC-Q101 qualified
- Low power loss, high efficiency
- Ideal for automated placement
- High surge current capability
- Moisture sensitivity level: level 1, per J-STD-020
- RoHS Compliant
- Halogen-free

### APPLICATIONS

- Low voltage, high frequency
- DC/DC converter
- Freewheeling diodes
- Reverse battery protection
- Car lighting

### MECHANICAL DATA

- Case: ThinDPAK
- Molding compound meets UL 94V-0 flammability rating
- Terminal: Matte tin plated leads, solderable per J-STD-002
- Meet JESD 201 class 2 whisker test
- Polarity: As marked
- Weight: 0.21g (approximately)

KEY PARAMETERS		
PARAMETER	VALUE	UNIT
$I_F$	20	A
$V_{RRM}$	120	V
$I_{FSM}$	240	A
$T_{J\ MAX}$	175	°C
Package	ThinDPAK	
Configuration	Common cathode	

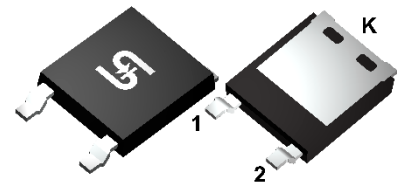

ThinDPAK

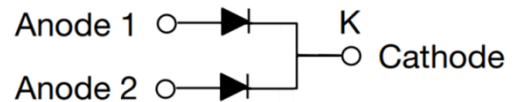

ABSOLUTE MAXIMUM RATINGS ( $T_A = 25^\circ\text{C}$ unless otherwise noted)			
PARAMETER	SYMBOL	VALUE	UNIT
Repetitive peak reverse voltage	$V_{RRM}$	120	V
Reverse voltage, total rms value	$V_{R(RMS)}$	84	V
Forward current, per leg / per device	$I_F$	10 / 20	A
Peak forward surge current, 8.3ms single half sine-wave superimposed on rated load	$I_{FSM}$	240	A
Junction temperature	$T_J$	- 55 to +175	°C
Storage temperature	$T_{STG}$	- 55 to +175	°C

**THERMAL PERFORMANCE**

PARAMETER	SYMBOL	TYP	UNIT
Junction-to-lead thermal resistance per leg <sup>(1)</sup>	R <sub>θJL</sub>	1.5	°C/W
Junction-to-ambient thermal resistance per leg <sup>(2)</sup>	R <sub>θJA</sub>	7.3	°C/W
Junction-to-case thermal resistance per leg <sup>(2)</sup>	R <sub>θJC</sub>	2.4	°C/W

**Thermal Performance Note:**

1. With ideal heat sink
2. Mounted on Heat sink with 4" x 6" x 0.25" Al-Plate

**ELECTRICAL SPECIFICATIONS** (T<sub>A</sub> = 25°C unless otherwise noted)

PARAMETER	CONDITIONS	SYMBOL	TYP	MAX	UNIT
Forward voltage per leg <sup>(1)</sup>	I <sub>F</sub> = 5A, T <sub>J</sub> = 25°C	V <sub>F</sub>	0.69	-	V
	I <sub>F</sub> = 10A, T <sub>J</sub> = 25°C		0.77	0.85	V
	I <sub>F</sub> = 5A, T <sub>J</sub> = 125°C		0.56	-	V
	I <sub>F</sub> = 10A, T <sub>J</sub> = 125°C		0.64	0.71	V
Reverse current @ rated V <sub>R</sub> per leg <sup>(2)</sup>	T <sub>J</sub> = 25°C	I <sub>R</sub>	-	5	μA
	T <sub>J</sub> = 125°C		-	4	mA
Junction capacitance per leg	1MHz, V <sub>R</sub> = 4.0V	C <sub>J</sub>	425	-	pF

**Notes:**

1. Pulse test with PW = 0.3ms
2. Pulse test with PW = 30ms

**ORDERING INFORMATION**

ORDERING CODE	PACKAGE	PACKING
TSAD20H120CH	ThinDPAK	4,500 / Tape & Reel

**CHARACTERISTICS CURVES**

( $T_A = 25^\circ\text{C}$  unless otherwise noted)

**Fig.1 Forward Current Derating Curve**

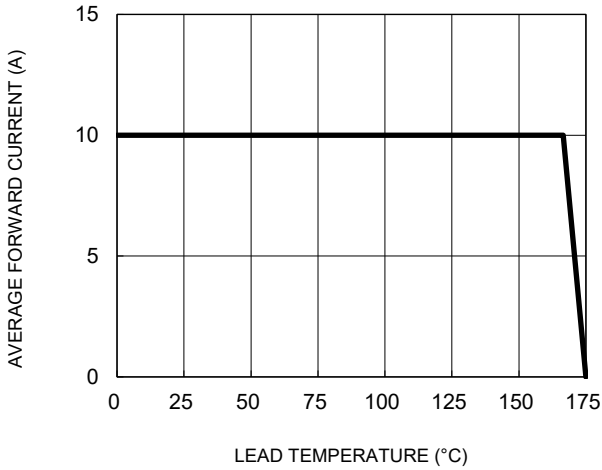

**Fig.2 Typical Junction Capacitance**

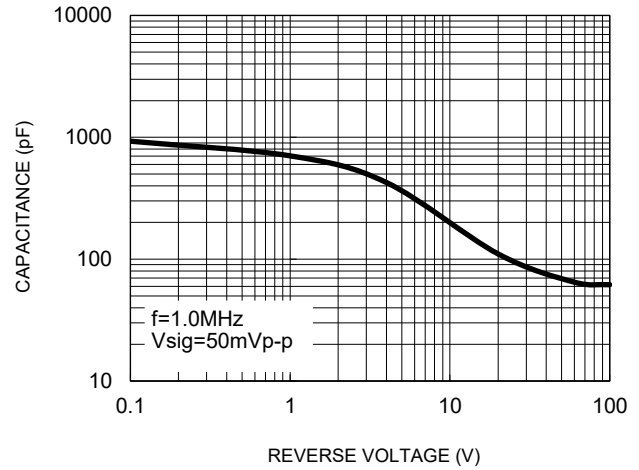

**Fig.3 Typical Reverse Characteristics**

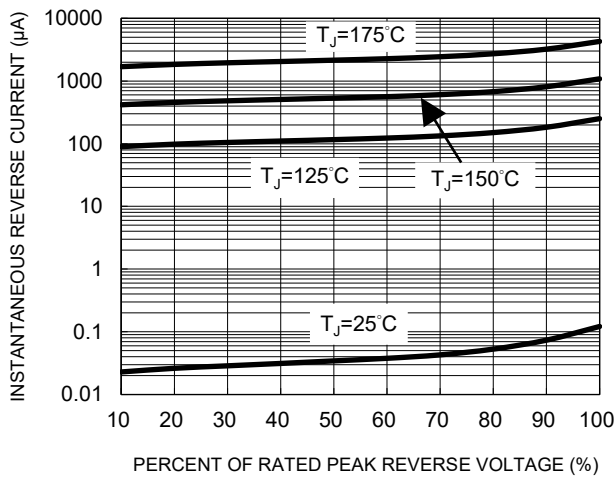

**Fig.4 Typical Forward Characteristics**

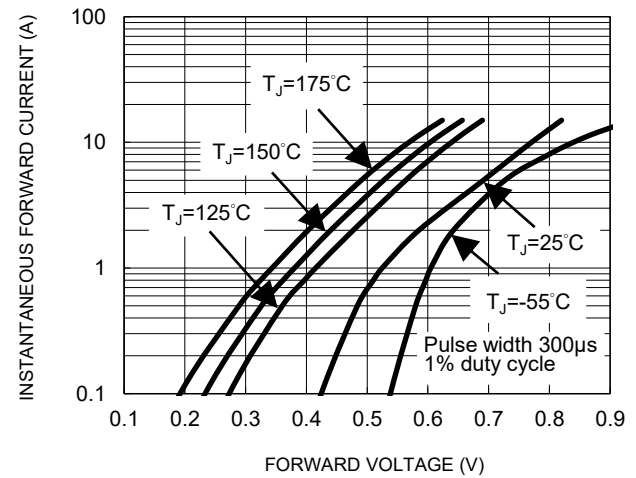

**Fig.5 Typical Forward Power Dissipation vs. Forward Current**

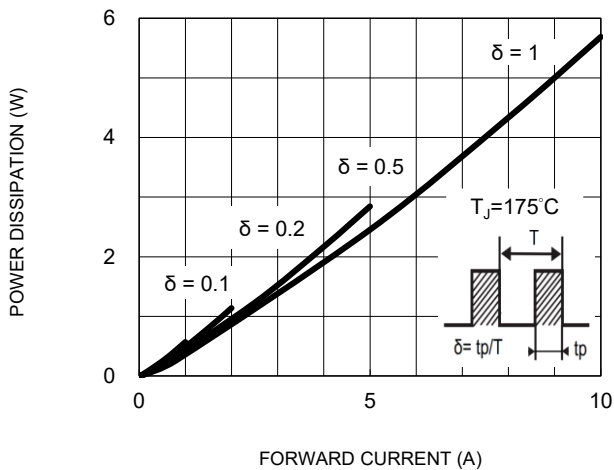

**CHARACTERISTICS CURVES**

(T<sub>A</sub> = 25°C unless otherwise noted)

**Fig.6 Typical Transient Thermal Characteristics**

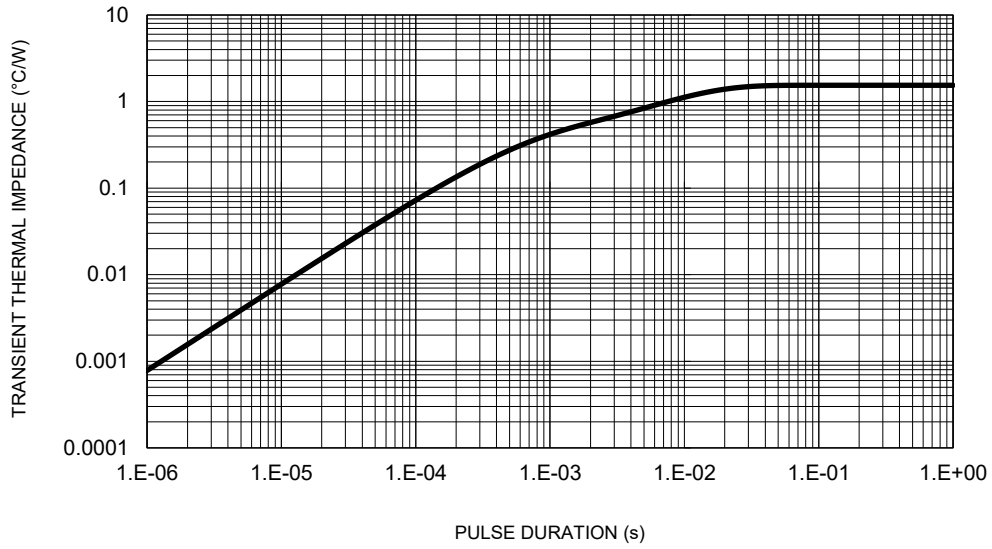

**PACKAGE OUTLINE DIMENSIONS**

**ThinDPAK**

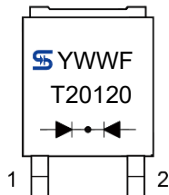
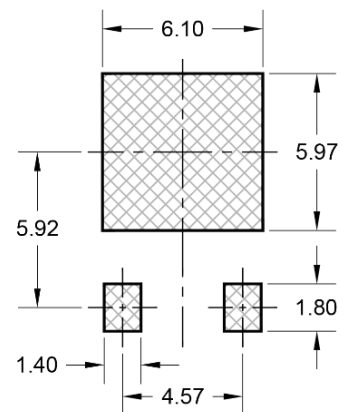
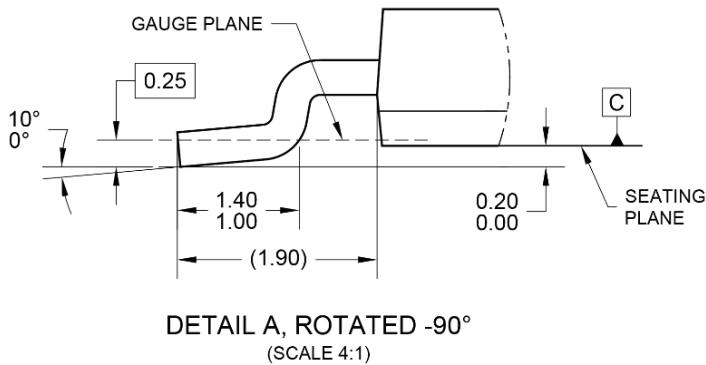
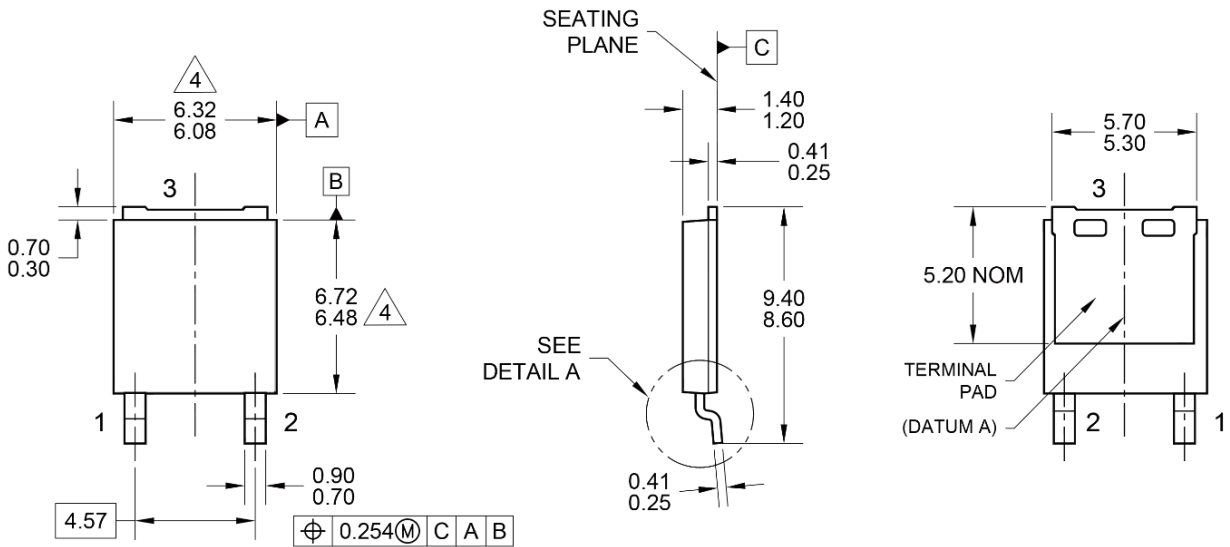

**MARKING DIAGRAM**

YWW = DATE CODE  
F = FACTORY CODE

**NOTES: UNLESS OTHERWISE SPECIFIED**

1. ALL DIMENSIONS ARE IN MILLIMETERS.
2. DIMENSIONING AND TOLERANCING PER ASME Y14.5M-1994.
3. PACKAGE OUTLINE REFERENCE: JEDEC TO-252, VARIATION AE, ISSUE F.
4. MOLDED PLASTIC BODY DIMENSIONS DO NOT INCLUDE MOLD FLASH, PROTRUSION, OR GATE BURRS.
5. DWG NO. REF: HQ2SD07-TDPAK-065 REV A.

## **Notice**

Specifications of the products displayed herein are subject to change without notice. TSC or anyone on its behalf assumes no responsibility or liability for any errors or inaccuracies.

Purchasers are solely responsible for the choice, selection, and use of TSC products and TSC assumes no liability for application assistance or the design of Purchasers' products.

Information contained herein is intended to provide a product description only. No license, express or implied, to any intellectual property rights is granted by this document. Except as provided in TSC's terms and conditions of sale for such products, TSC assumes no liability whatsoever, and disclaims any express or implied warranty, relating to sale and/or use of TSC products including liability or warranties relating to fitness for a particular purpose, merchantability, or infringement of any patent, copyright, or other intellectual property right.

The products shown herein are not designed for use in medical, life-saving, or life-sustaining applications. Customers using or selling these products for use in such applications do so at their own risk and agree to fully indemnify TSC for any damages resulting from such improper use or sale.