

Uni-directional ESD Protection Diode

DESCRIPTIONS

The TESDA28VU18P1Q1 is Uni-directional ESD rated clamping cell to protect power interfaces, or one control line, or one low speed data line in an electronic system. It has been specifically designed to protect sensitive electronic components which are connected to power and control lines from over-voltage damage by Electrostatic Discharging (ESD), and Lightning.

ESD protection device in a ultra small DFN1006 Surface-Mounted Device (SMD) plastic package designed to protect two automotive In-vehicle network bus lines from the damage caused by Electrostatics discharge (ESD) and other transients.

The TESDA28VU18P1Q1 may be used to provide ESD protection up to $\pm 15\text{kV}$ (contact and air discharge) according to IEC61000-4-2 and withstand peak pulse current up to 1.7A (8/20 μs) according to IEC61000-4-5.

FEATURES

- AEC-Q101 qualified
- Wettable flank
- Provide ESD protection for each channel to IEC 61000-4-2 (ESD) $\pm 15\text{kV}$ (air), $\pm 15\text{kV}$ (contact) IEC 61000-4-5 (Lightning) 1.7A (8/20 μs)
- Suitable for 28V and below, operating voltage applications
- Small packages save board space
- Protect one I/O line or one power line
- Moisture sensitivity level: level 1, per J-STD-020
- RoHS Compliant
- Halogen-Free

APPLICATION

- Automotive low speed data lines
- Portable Instrumentation
- General Purpose I/O
- Mobile & Handhelds

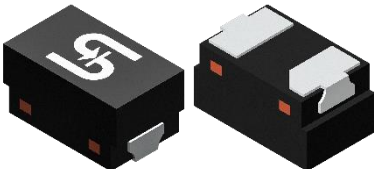
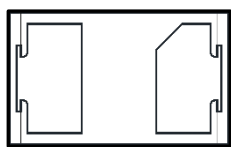
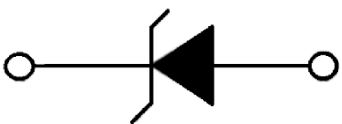

PACKAGE: DFN1006-2LW	PIN CONFIGURATION	CIRCUIT DIAGRAM
		

ABSOLUTE MAXIMUM RATINGS ($T_A = 25^\circ\text{C}$ unless otherwise noted)			
PARAMETER	SYMBOL	VALUE	UNIT
Peak pulse power ($t_p = 8/20\mu\text{s}$)	P_{PK}	100	W
Peak pulse current ($t_p = 8/20\mu\text{s}$)	I_{PP}	1.7	A
ESD according to IEC61000-4-2 air discharge	V_{ESD}	± 15	kV
ESD according to IEC61000-4-2 contact discharge		± 15	kV
Operating junction temperature range	T_J	-55 to +150	$^\circ\text{C}$
Storage temperature range	T_{STG}	-55 to +150	$^\circ\text{C}$

ELECTRICAL SPECIFICATIONS ($T_A = 25^\circ\text{C}$ unless otherwise noted)						
PARAMETER	CONDITIONS	SYMBOL	MIN	TYP	MAX	UNIT
Reverse working voltage		V_{RWM}	-	-	28	V
Reverse breakdown voltage	$I_R = 5\text{mA}$, $T_J = 25^\circ\text{C}$	V_{BR}	31.3	33.8	34.7	V
Reverse leakage current	$V_{RWM} = 28\text{V}$, $T_J = 25^\circ\text{C}$	I_R	-	0.3	10	nA
Clamping voltage ⁽¹⁾	$I_{PP} = 1.7\text{A}$, $t_p = 8/20\mu\text{s}$	V_C	40	41.6	59	V
Clamping voltage ⁽²⁾	$I_{TLP} = 2\text{A}$, $t_p = 100\text{ns}$	V_{CL}	-	35.9	-	V
	$I_{TLP} = 6\text{A}$, $t_p = 100\text{ns}$		-	38.4	-	V
Junction capacitance	1MHz, $V_R = 0\text{V}$	C_J	13.6	16.4	18.6	pF

Notes:

1. Non-repetitive current pulse, according to IEC61000-4-5.

ORDERING INFORMATION		
ORDERING CODE	PACKAGE	PACKING
TESDA28VU18P1Q1 RNG	DFN1006-2LW	10,000 / 7" Tape & Reel

CHARACTERISTICS CURVES

($T_A = 25^\circ\text{C}$ unless otherwise noted)

Fig.1 Peak Pulse Power vs. Junction Temperature

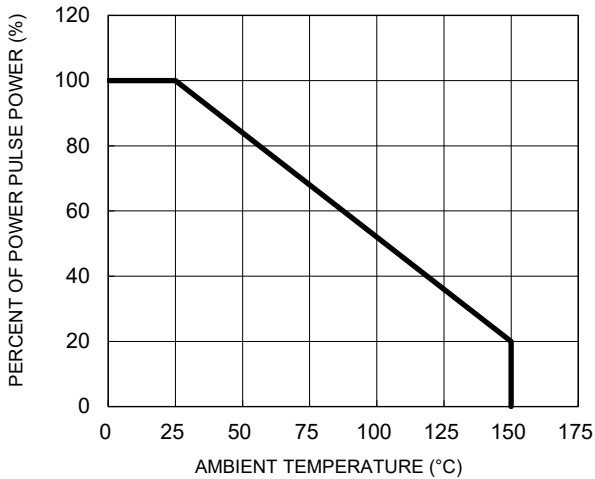

Fig.2 Non-Repetitive Peak Pulse Power vs. Pulse Time

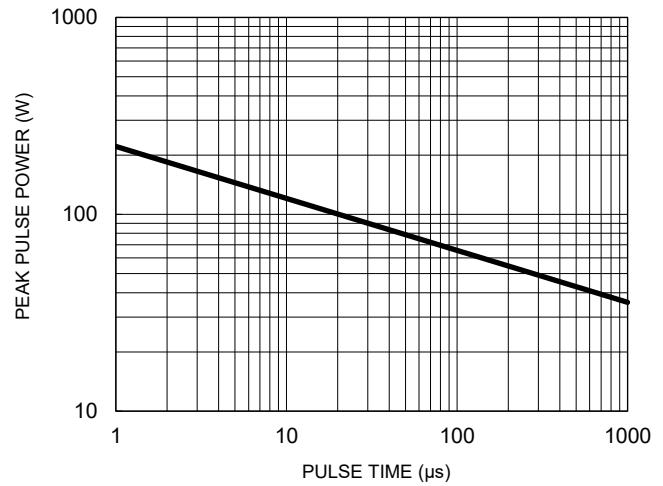

Fig.3 Clamping Voltage vs. Peak Pulse Current

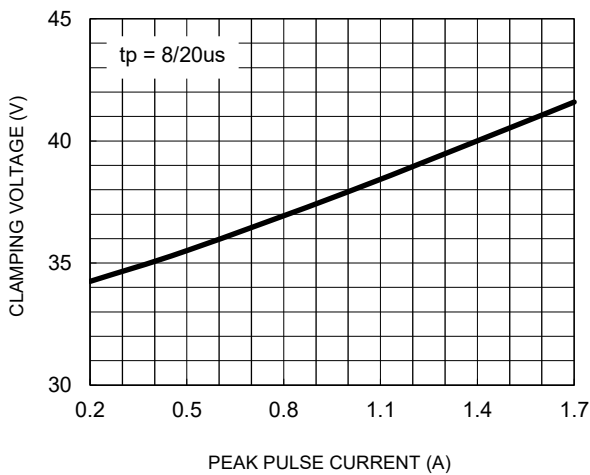

Fig.4 Capacitance vs. Reverse Voltage

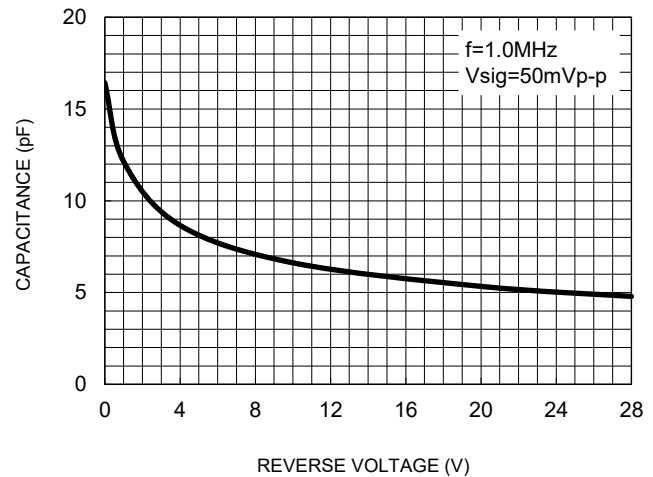

Fig.5 8/20μs pulse waveform per IEC61000-4-5

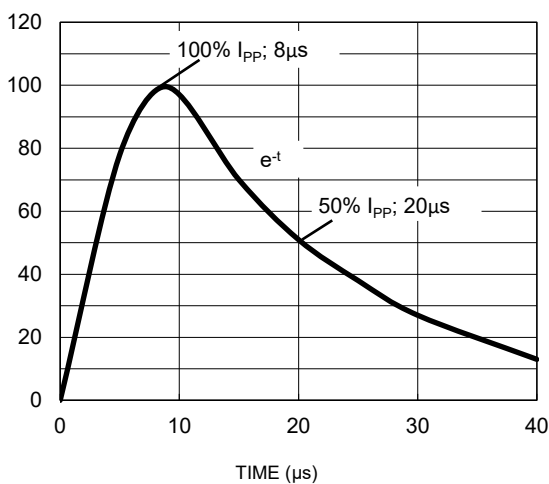
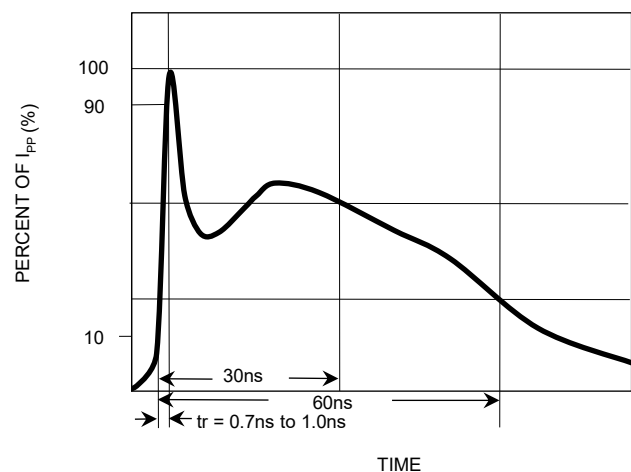

Fig.6 ESD pulse waveform per IEC61000-4-2



APPLICATION INFORMATION

Device Connection

The TESDA28VU18P1Q1 is designed for protection from the damage caused by ESD and surge pulses.

The usage of the TESDA28VU18P1Q1 is shown in Fig1.Protected line.

To minimize parasitic inductance in the board traces, all path lengths connected to the pins of TESDA28VU18P1Q1 should be kept as short as possible.

To obtain enough suppression of ESD transient, a good circuit board is critical. Thus, the following guidelines are recommended:

- Let the path length between the protected lines and the TESDA28VU18P1Q1 minimize.
- Place the TESDA28VU18P1Q1 near the input terminals or connectors to restrict transient coupling.
- The ESD current return path to ground should be kept as short as possible.
- Use ground plane whenever possible.

Fig.1 ESD protection by TESDA28VU18P1Q1

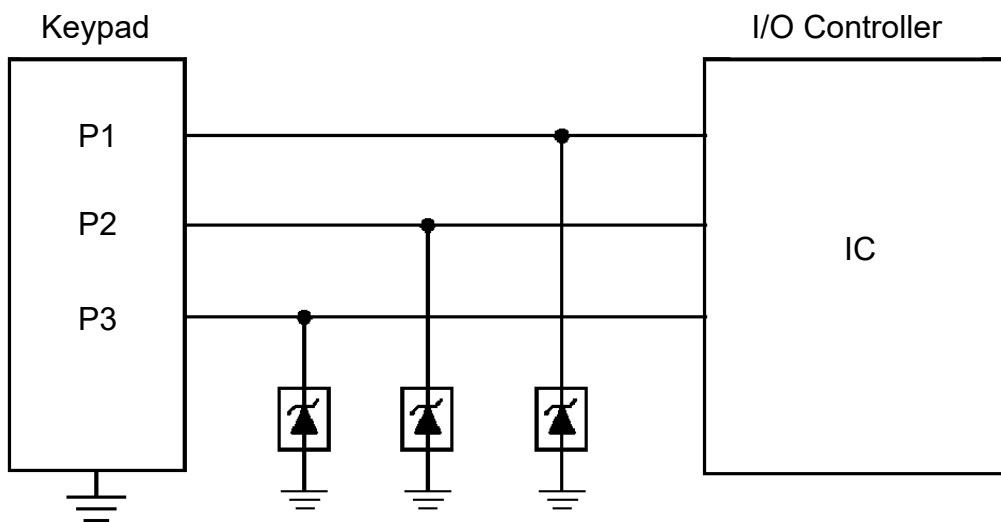

PACKAGE OUTLINE DIMENSIONS

DFN1006-2LW

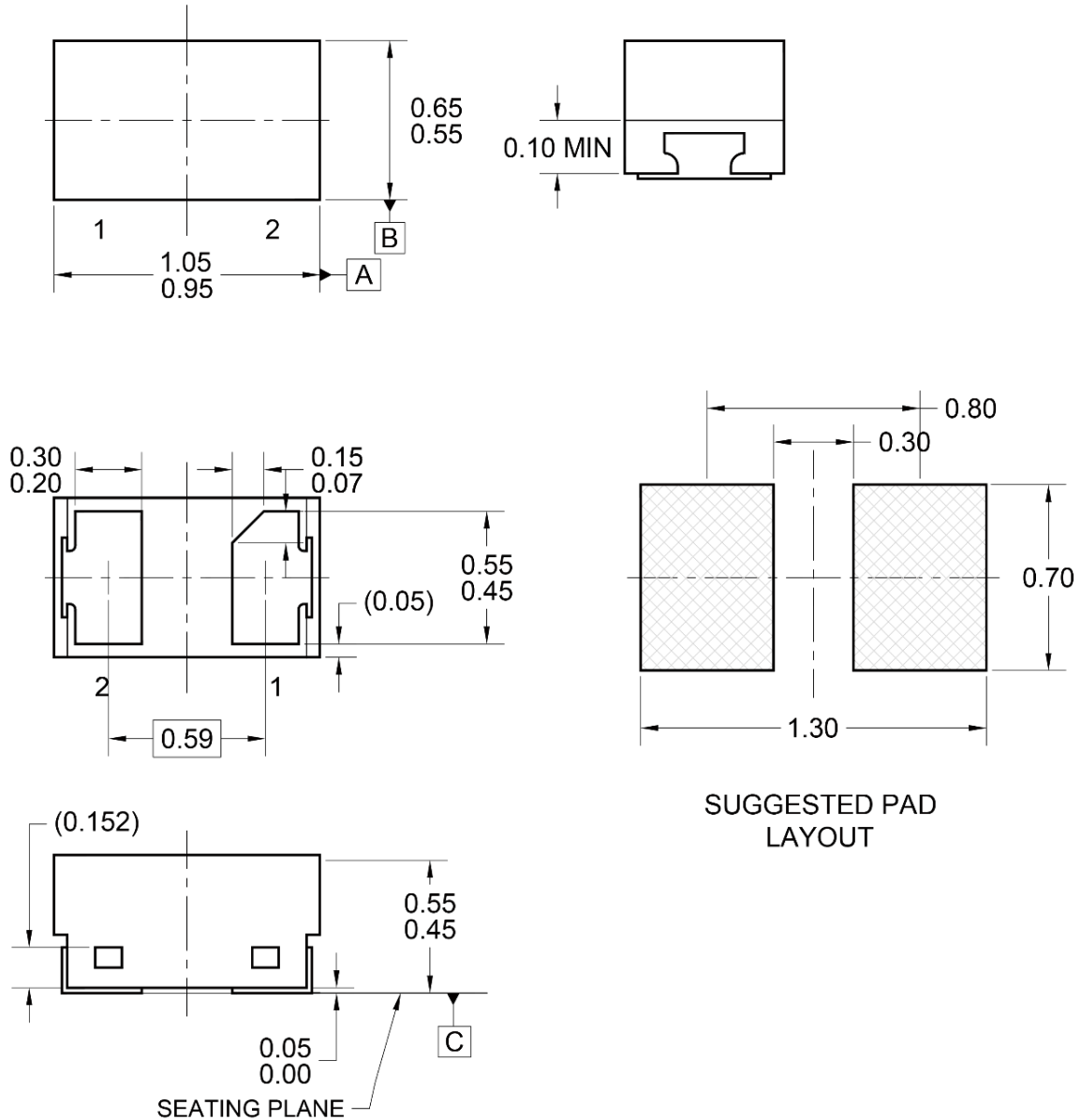

SUGGESTED PAD LAYOUT

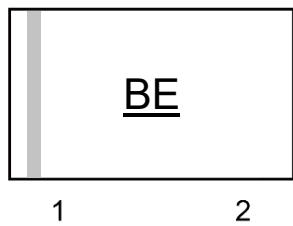

MARKING DIAGRAM

NOTES: UNLESS OTHERWISE SPECIFIED

1. ALL DIMENSIONS ARE IN MILLIMETERS.
2. DIMENSIONING AND TOLERANCING PER ASME Y14.5M-1994.
3. SUGGESTED PAD LAYOUT IS FOR REFERENCE PURPOSE ONLY.
4. DWG NO. REF: HQ2SD07-DFN1006_2LW-123 REV B.

Notice

Specifications of the products displayed herein are subject to change without notice. TSC or anyone on its behalf assumes no responsibility or liability for any errors or inaccuracies.

Purchasers are solely responsible for the choice, selection, and use of TSC products and TSC assumes no liability for application assistance or the design of Purchasers' products.

Information contained herein is intended to provide a product description only. No license, express or implied, to any intellectual property rights is granted by this document. Except as provided in TSC's terms and conditions of sale for such products, TSC assumes no liability whatsoever, and disclaims any express or implied warranty, relating to sale and/or use of TSC products including liability or warranties relating to fitness for a particular purpose, merchantability, or infringement of any patent, copyright, or other intellectual property right.

The products shown herein are not designed for use in medical, life-saving, or life-sustaining applications. Customers using or selling these products for use in such applications do so at their own risk and agree to fully indemnify TSC for any damages resulting from such improper use or sale.