

Bi-directional ESD Protection Diode

DESCRIPTIONS

The TESDA24VB6P02CX is a Bidirectional ESD rated clamping cell to protect power interfaces, or control line, or low speed data line in an electronic system. It has been specifically designed to protect sensitive electronic components which are connected to power and control lines from over-voltage damage by Electrostatic Discharging (ESD), and Lightning.

ESD protection device in a small SOT-23 Surface-Mounted Device (SMD) plastic package designed to protect two automotive In-vehicle network bus lines from the damage caused by Electrostatics discharge (ESD) and other transients.

The TESDA24VB6P02CX may be used to provide ESD protection up to $\pm 20\text{kV}$ (contact and air discharge) according to IEC61000-4-2, and withstand peak pulse current up to 2.6A (8/20 μs) according to IEC61000-4-5

FEATURES

- AEC-Q101 qualified
- ESD protection for 2 lines with bidirectional
- Provide ESD protection for each channel to IEC61000-4-2 (ESD) $\pm 20\text{kV}$ (air), $\pm 20\text{kV}$ (contact) IEC61000-4-5 (Lightning) 2.6A (8/20 μs)
- Suitable for 24V and below, operating voltage applications
- Protect I/O line or power line.
- Moisture sensitivity level: level 1, per J-STD-020
- RoHS Compliant
- Halogen-Free

APPLICATION

- ESD protection for In-vehicle network lines in automotive environments
- CAN Bus
- CAN Bus FD (flexible data rate)
- FlexRay
- SENT

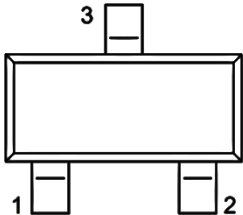
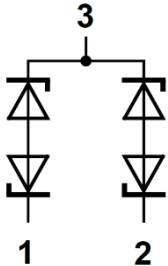

PACKAGE: SOT-23	PIN CONFIGURATION	CIRCUIT DIAGRAM
		

ABSOLUTE MAXIMUM RATINGS ($T_A = 25^\circ\text{C}$ unless otherwise noted)			
PARAMETER	SYMBOL	VALUE	UNIT
Peak pulse power ($t_p = 8/20\mu\text{s}$)	P_{PK}	110	W
Peak pulse current ($t_p = 8/20\mu\text{s}$)	I_{PP}	2.6	A
ESD according to IEC61000-4-2 air discharge	V_{ESD}	± 20	kV
ESD according to IEC61000-4-2 contact discharge		± 20	kV
Junction temperature range	T_J	-55 to +150	$^\circ\text{C}$
Storage temperature range	T_{STG}	-55 to +150	$^\circ\text{C}$

ELECTRICAL SPECIFICATIONS ($T_A = 25^\circ\text{C}$ unless otherwise noted)						
PARAMETER	CONDITIONS	SYMBOL	MIN	TYP	MAX	UNIT
Reverse working voltage		V_{RWM}	-	-	24	V
Reverse breakdown voltage	$I_R = 10\text{mA}$, $T_J = 25^\circ\text{C}$	V_{BR}	25.5	-	35.5	V
Reverse leakage current	$V_{RWM} = 24\text{V}$	I_R	-	0.3	50	nA
Clamping voltage ⁽¹⁾	$I_{PP} = 1.0\text{A}$, $t_p = 8/20\mu\text{s}$	V_C	-	34	42	V
	$I_{PP} = 2.6\text{A}$, $t_p = 8/20\mu\text{s}$		-	42.3	-	V
Clamping voltage ⁽²⁾	$I_{TLP} = 1\text{A}$, $t_p = 100\text{ns}$	V_{CL}	-	31	-	V
	$I_{TLP} = 6\text{A}$, $t_p = 100\text{ns}$		-	36	-	V
Junction capacitance	1MHz, $V_R = 2.5\text{V}$	C_J	-	5.6	6.0	pF

Notes:

1. Non-repetitive current pulse, according to IEC61000-4-5.
2. TLP parameter: $Z_0 = 50\ \Omega$, $t_p = 100\text{ns}$, $t_r = 2\text{ns}$

ORDERING INFORMATION		
ORDERING CODE	PACKAGE	PACKING
TESDA24VB6P02CX RFG	SOT-23	3,000 / 7" Tape & Reel

CHARACTERISTICS CURVES

($T_A = 25^\circ\text{C}$ unless otherwise noted)

Fig.1 Peak Pulse Power vs. Junction Temperature

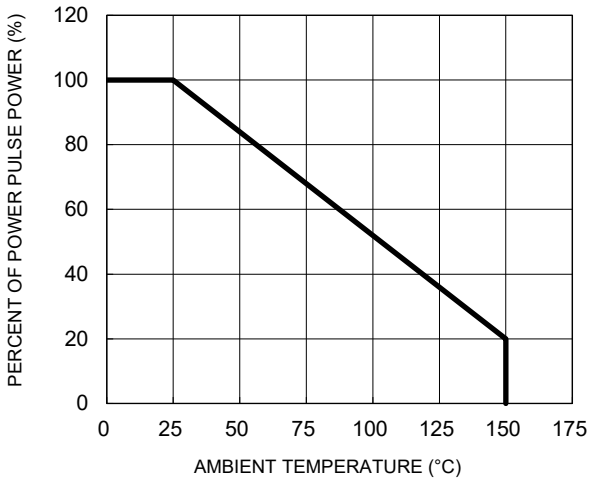

Fig.2 Non-Repetitive Peak Pulse Power vs. Pulse Time

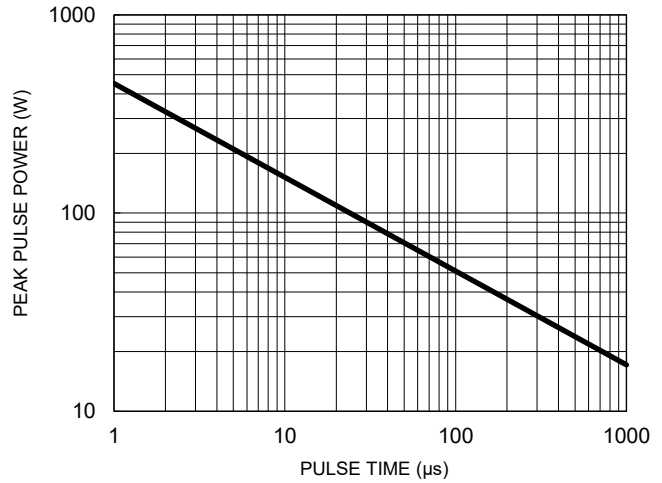

Fig.3 Clamping Voltage vs. Peak Pulse Current

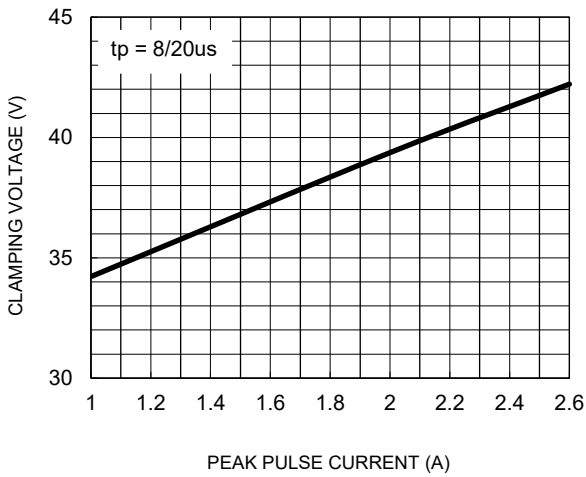

Fig.4 Capacitance vs. Reverse Voltage

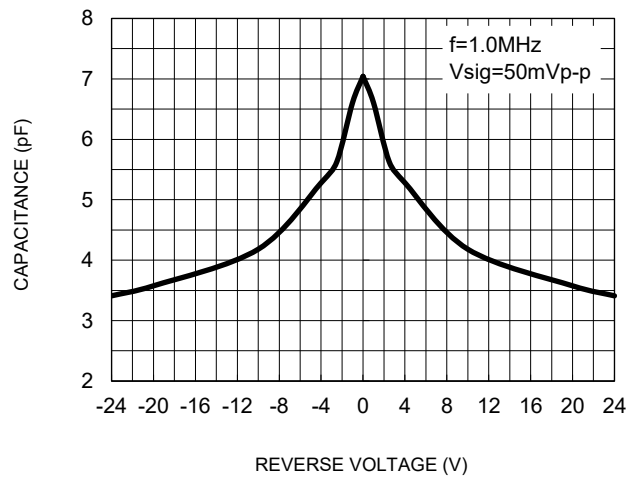

Fig.5 8/20μs pulse waveform per IEC61000-4-5

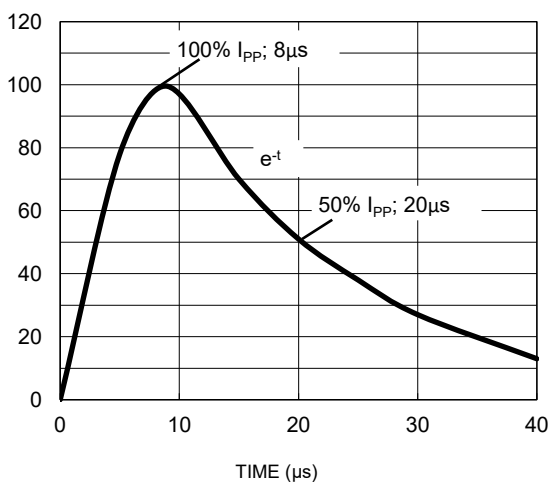
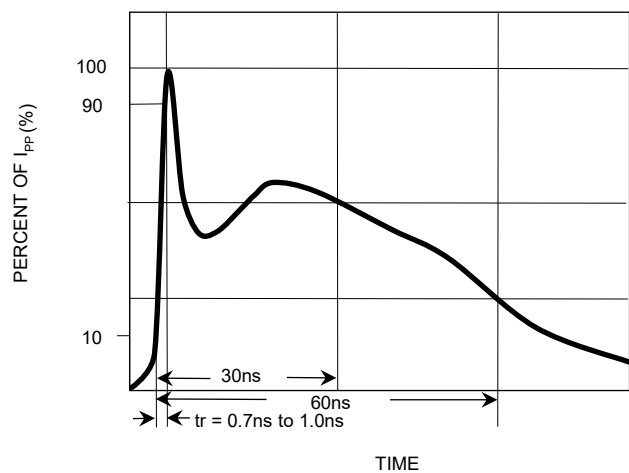

Fig.6 ESD pulse waveform per IEC61000-4-2



APPLICATION INFORMATION

Device Connection

The TESDA24VB6P02CX is designed to protect one line against system ESD Lightning pulses by clamping it to an acceptable reference. It provides bidirectional protection.

The usage of the TESDA24VB6P02CX is shown in Fig1.Protected line.

To minimize parasitic inductance in the board traces, all path lengths connected to the pins of TESDA24VB6P02CX should be kept as short as possible.

To obtain enough suppression of ESD transient, a good circuit board is critical. Thus, the following guidelines are recommended:

- Let the path length between the protected lines and the TESDA24VB6P02CX minimize.
- Place the TESDA24VB6P02CX near the input terminals or connectors to restrict transient coupling.
- The ESD current return path to ground should be kept as short as possible.
- Use ground plane whenever possible.

Fig.1 ESD protection by TESDA24VB6P02CX

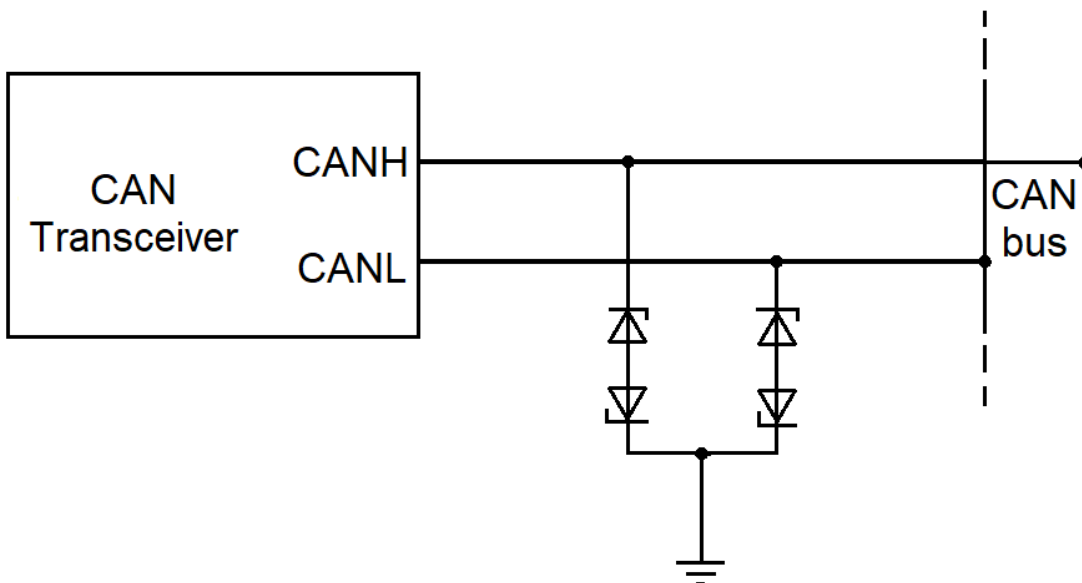

PACKAGE OUTLINE DIMENSIONS

SOT-23

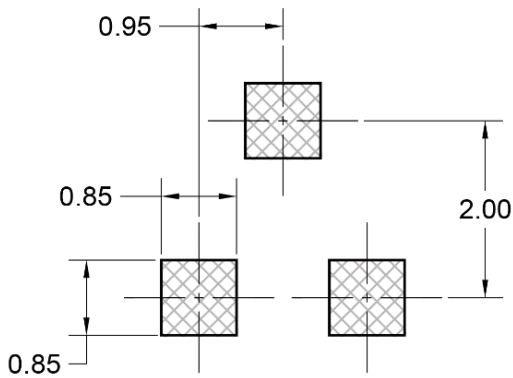
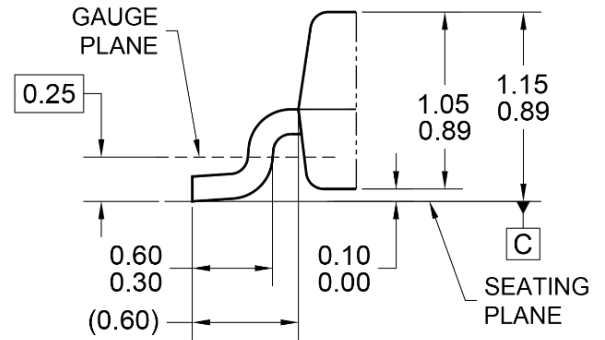
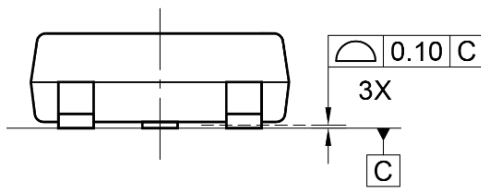
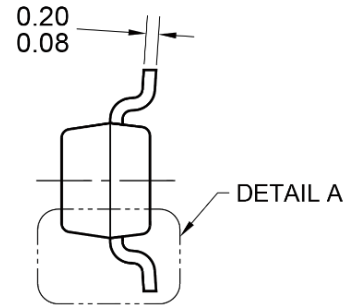
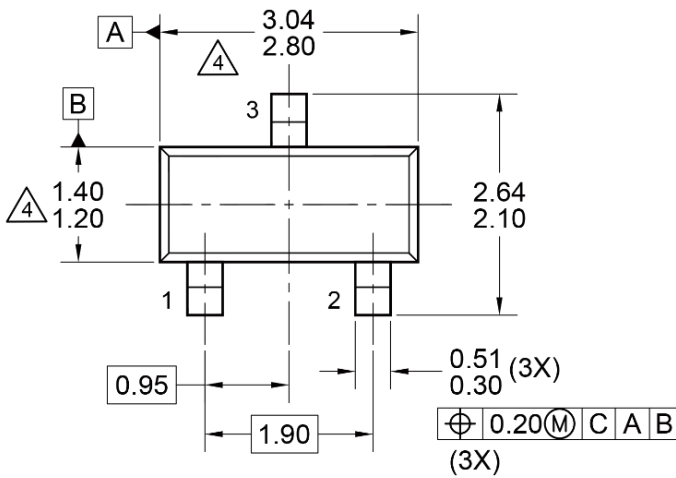

SUGGESTED PAD LAYOUT

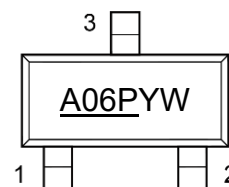

MARKING DIAGRAM

NOTES: UNLESS OTHERWISE SPECIFIED

1. ALL DIMENSIONS ARE IN MILLIMETERS.
2. DIMENSIONING AND TOLERANCING PER ASME Y14.5M-1994.
3. PACKAGE OUTLINE REFERENCE: JEDEC TO-236, ISSUE H, VARIATION AA.
4. MOLDED PLASTIC BODY DIMENSIONS DO NOT INCLUDE MOLD FLASH, PROTRUSIONS OR GATE BURRS.
5. DWG NO. REF: HQ2SD07-SOT23JEDEC-104 REV B.

- P/N = A06P
Y = Year code
W = Bi-week code (A~Z)

Notice

Specifications of the products displayed herein are subject to change without notice. TSC or anyone on its behalf assumes no responsibility or liability for any errors or inaccuracies.

Purchasers are solely responsible for the choice, selection, and use of TSC products and TSC assumes no liability for application assistance or the design of Purchasers' products.

Information contained herein is intended to provide a product description only. No license, express or implied, to any intellectual property rights is granted by this document. Except as provided in TSC's terms and conditions of sale for such products, TSC assumes no liability whatsoever, and disclaims any express or implied warranty, relating to sale and/or use of TSC products including liability or warranties relating to fitness for a particular purpose, merchantability, or infringement of any patent, copyright, or other intellectual property right.

The products shown herein are not designed for use in medical, life-saving, or life-sustaining applications. Customers using or selling these products for use in such applications do so at their own risk and agree to fully indemnify TSC for any damages resulting from such improper use or sale.