

## 400W, 5V - 75V Surface Mount Transient Voltage Suppressor

### FEATURES

- AEC-Q101 qualified
- Unidirectional and bidirectional are available
- Low power loss, high efficiency
- Ideal for automated placement
- Excellent clamping capability
- Meets ISO 7637-2 (Pulse 1/2a/2b/3a/3b)
- IEC-61000-4-2 ESD 30kV(Air), 30kV (Contact)
- Moisture sensitivity level: level 1, per J-STD-020
- RoHS Compliant
- Halogen-free

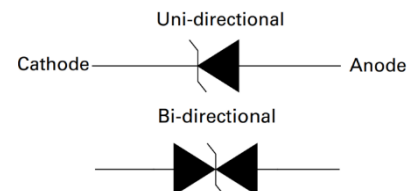
### APPLICATIONS

- Protect sensitive circuits from damage by high voltage transients
- Lighting, ESD transient voltage protection of IC, system
- Inductive switching load protection of IC, system
- Electrical Fast Transient Immunity protection of IC, system

### MECHANICAL DATA

- Case: SOD-123W
- Molding compound meets UL 94V-0 flammability rating
- Terminal: Matte tin-plated leads, solderable per J-STD-002
- Meet JESD 201 class 2 whisker test
- Polarity: Indicated by cathode band
- Weight: 0.015g (approximately)

KEY PARAMETERS			
PARAMETER		VALUE	UNIT
$V_{WM}$	Uni	5.0 - 75	V
	Bi	6.5 - 64	V
$V_{BR}$	Uni	6.4 - 92.1	V
	Bi	7.2 - 78.6	V
$P_{PPM}$		400	W
$T_{JMAX}$		175	°C
Package		SOD-123W	


**SOD-123W**


ABSOLUTE MAXIMUM RATINGS ( $T_A = 25^\circ\text{C}$ unless otherwise noted)			
PARAMETER	SYMBOL	VALUE	UNIT
Non-repetitive peak impulse power dissipation with 10/1000us waveform <sup>(1)</sup>	$P_{PPM}$	400	W
Steady state power dissipation at $T_L = 50^\circ\text{C}$ <sup>(2)</sup>	$P_D$	7.9	W
Junction temperature	$T_J$	-55 to +175	°C
Storage temperature	$T_{STG}$	-55 to +175	°C

#### Notes:

1. Non-repetitive current pulse per Fig.6 and derated above  $T_A = 25^\circ\text{C}$  per Fig.1
2. Units mounted on PCB (5mm x 5mm Cu pad test board)

<b>THERMAL PERFORMANCE</b>			
<b>PARAMETER</b>	<b>SYMBOL</b>	<b>TYP</b>	<b>UNIT</b>
Junction-to-lead thermal resistance for unidirectional	$R_{\theta JL}$	15.9	$^{\circ}\text{C/W}$
Junction-to-ambient thermal resistance for unidirectional	$R_{\theta JA}$	65.1	$^{\circ}\text{C/W}$
Junction-to-case thermal resistance for unidirectional	$R_{\theta JC}$	14.4	$^{\circ}\text{C/W}$

**Thermal Performance Note:** Units mounted on PCB (5mm x 5mm Cu pad test board)

<b>ELECTRICAL SPECIFICATIONS</b> ( $T_A = 25^{\circ}\text{C}$ unless otherwise noted)								
Part number (Unidirectional)	Device marking	Breakdown voltage $V_{BR@I_T}$ (V) (Note 1)		Test current $I_T$ (mA)	Working stand-off voltage $V_{WM}$ (V)	Maximum blocking leakage current $I_R@V_{WM}$ ( $\mu\text{A}$ ) (Note 1)	Maximum peak impulse current $I_{PPM}$ (A) $t_p = 10/1000 \mu\text{s}$	Maximum clamping voltage $V_C@I_{PPM}$ (V)
		Min	Max					
SMF4L5.0AH	4W05U	6.40	7.00	10	5.0	800	40.1	9.2
SMF4L6.0AH	4W06U	6.67	7.37	10	6.0	800	35.9	10.3
SMF4L6.5AH	4W6U5	7.22	7.98	10	6.5	500	33.1	11.2
SMF4L7.0AH	4W07U	7.78	8.60	10	7.0	200	30.9	12.0
SMF4L7.5AH	4W7U5	8.33	9.21	1	7.5	100	28.7	12.9
SMF4L8.0AH	4W08U	8.89	9.83	1	8.0	50	27.2	13.6
SMF4L8.5AH	4W8U5	9.44	10.4	1	8.5	20	25.7	14.4
SMF4L9.0AH	4W09U	10.0	11.1	1	9.0	5	26.4	15.4
SMF4L10AH	4W10U	11.1	12.3	1	10	5	23.5	17.0
SMF4L11AH	4W11U	12.2	13.5	1	11	1	22.0	18.2
SMF4L12AH	4W12U	13.3	14.7	1	12	1	20.1	19.9
SMF4L13AH	4W13U	14.4	15.9	1	13	1	18.6	21.5
SMF4L14AH	4W14U	15.6	17.2	1	14	1	17.2	23.2
SMF4L15AH	4W15U	16.7	18.5	1	15	1	16.4	24.4
SMF4L16AH	4W16U	17.8	19.7	1	16	1	15.4	26.0
SMF4L17AH	4W17U	18.9	20.9	1	17	1	14.5	27.6
SMF4L18AH	4W18U	20.0	22.1	1	18	1	13.7	29.2
SMF4L20AH	4W20U	22.2	24.5	1	20	1	12.3	32.4
SMF4L22AH	4W22U	24.4	26.9	1	22	1	11.3	35.5
SMF4L24AH	4W24U	26.7	29.5	1	24	1	10.3	38.9
SMF4L26AH	4W26U	28.9	31.9	1	26	1	9.5	42.1
SMF4L28AH	4W28U	31.1	34.4	1	28	1	8.8	45.4
SMF4L30AH	4W30U	33.3	36.8	1	30	1	8.3	48.4
SMF4L33AH	4W33U	36.7	40.6	1	33	1	7.5	53.3
SMF4L36AH	4W36U	40.0	44.2	1	36	1	6.9	58.1
SMF4L40AH	4W40U	44.4	49.1	1	40	1	6.2	64.5
SMF4L43AH	4W43U	47.8	52.8	1	43	1	5.8	69.4

<b>ELECTRICAL SPECIFICATIONS</b> ( $T_A = 25^\circ\text{C}$ unless otherwise noted)								
Part number (Unidirectional)	Device marking	Breakdown voltage $V_{BR@I_T}$ (V) (Note 1)		Test current $I_T$ (mA)	Working stand-off voltage $V_{WM}$ (V)	Maximum blocking leakage current $I_R@V_{WM}$ ( $\mu\text{A}$ ) (Note 1)	Maximum peak impulse current $I_{PPM}$ (A) $t_p = 10/1000 \mu\text{s}$	Maximum clamping voltage $V_C@I_{PPM}$ (V)
		Min	Max					
SMF4L45AH	4W45U	50.0	55.3	1	45	1	5.5	72.7
SMF4L48AH	4W48U	53.3	58.9	1	48	1	5.2	77.4
SMF4L51AH	4W51U	56.7	62.7	1	51	1	4.9	82.4
SMF4L54AH	4W54U	60.0	66.3	1	54	1	4.6	87.1
SMF4L58AH	4W58U	64.4	71.2	1	58	1	4.3	93.6
SMF4L60AH	4W60U	66.7	73.7	1	60	1	4.1	96.8
SMF4L64AH	4W64U	71.1	78.6	1	64	1	3.9	103.0
SMF4L70AH	4W70U	77.8	86.0	1	70	1	3.5	113.0
SMF4L75AH	4W75U	83.3	92.1	1	75	1	3.3	121.0

**Notes:**

1. Pulse test with  $PW = 30\text{ms}$

**ELECTRICAL SPECIFICATIONS** ( $T_A = 25^\circ\text{C}$  unless otherwise noted)

Part number (Bidirectional)	Device marking	Breakdown voltage $V_{BR@I_T}$ (V) (Note 1)		Test current $I_T$ (mA)	Working stand-off voltage $V_{WM}$ (V)	Maximum blocking leakage current $I_R@V_{WM}$ ( $\mu\text{A}$ ) (Note 1)	Maximum peak impulse current $I_{PPM}$ (A) $t_p = 10/1000 \mu\text{s}$	Maximum clamping voltage $V_C@I_{PPM}$ (V)
		Min	Max					
SMF4L6.5CAH	4W6U5	7.22	7.98	10	6.5	500	33.1	11.2
SMF4L7.0CAH	4W07U	7.78	8.60	10	7.0	200	30.9	12.0
SMF4L7.5CAH	4W7U5	8.33	9.21	1	7.5	100	28.7	12.9
SMF4L8.0CAH	4W08U	8.89	9.83	1	8.0	50	27.2	13.6
SMF4L8.5CAH	4W8U5	9.44	10.4	1	8.5	20	25.7	14.4
SMF4L9.0CAH	4W09U	10.0	11.1	1	9.0	5	26.4	15.4
SMF4L10CAH	4W10U	11.1	12.3	1	10	5	23.5	17.0
SMF4L11CAH	4W11U	12.2	13.5	1	11	1	22.0	18.2
SMF4L12CAH	4W12U	13.3	14.7	1	12	1	20.1	19.9
SMF4L13CAH	4W13U	14.4	15.9	1	13	1	18.6	21.5
SMF4L14CAH	4W14U	15.6	17.2	1	14	1	17.2	23.2
SMF4L15CAH	4W15U	16.7	18.5	1	15	1	16.4	24.4
SMF4L16CAH	4W16U	17.8	19.7	1	16	1	15.4	26.0
SMF4L17CAH	4W17U	18.9	20.9	1	17	1	14.5	27.6
SMF4L18CAH	4W18U	20.0	22.1	1	18	1	13.7	29.2
SMF4L20CAH	4W20U	22.2	24.5	1	20	1	12.3	32.4
SMF4L22CAH	4W22U	24.4	26.9	1	22	1	11.3	35.5
SMF4L24CAH	4W24U	26.7	29.5	1	24	1	10.3	38.9
SMF4L26CAH	4W26U	28.9	31.9	1	26	1	9.5	42.1
SMF4L28CAH	4W28U	31.1	34.4	1	28	1	8.8	45.4
SMF4L30CAH	4W30U	33.3	36.8	1	30	1	8.3	48.4
SMF4L33CAH	4W33U	36.7	40.6	1	33	1	7.5	53.3
SMF4L36CAH	4W36U	40.0	44.2	1	36	1	6.9	58.1
SMF4L40CAH	4W40U	44.4	49.1	1	40	1	6.2	64.5
SMF4L43CAH	4W43U	47.8	52.8	1	43	1	5.8	69.4
SMF4L45CAH	4W45U	50.0	55.3	1	45	1	5.5	72.7
SMF4L48CAH	4W48U	53.3	58.9	1	48	1	5.2	77.4
SMF4L51CAH	4W51U	56.7	62.7	1	51	1	4.9	82.4
SMF4L54CAH	4W54U	60.0	66.3	1	54	1	4.6	87.1
SMF4L58CAH	4W58U	64.4	71.2	1	58	1	4.3	93.6
SMF4L60CAH	4W60U	66.7	73.7	1	60	1	4.1	96.8
SMF4L64CAH	4W64U	71.1	78.6	1	64	1	3.9	103.0

**Notes:**

1. Pulse test with  $PW = 30\text{ms}$

**ORDERING INFORMATION**

<b>ORDERING CODE</b>	<b>PACKAGE</b>	<b>PACKING</b>
SMF4LxAH <sup>(1)</sup>	SOD-123W	10,000 / Tape & Reel
SMF4LxCAH <sup>(2)</sup>	SOD-123W	10,000 / Tape & Reel

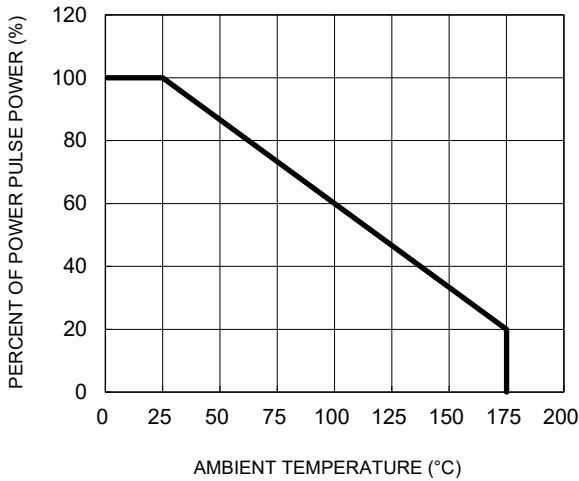
**Notes:**

1. "x" defines voltage from 5V(SMF4L5.0AH) to 75V(SMF4L75AH) for unidirectional
2. "x" defines voltage from 6.5V(SMF4L6.5CAH) to 64V(SMF4L64CAH) for bidirectional

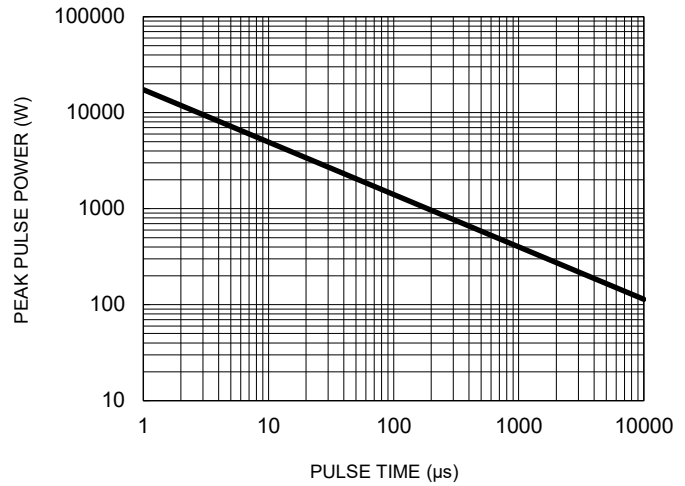
**CHARACTERISTICS CURVES**

( $T_A = 25^\circ\text{C}$  unless otherwise noted)

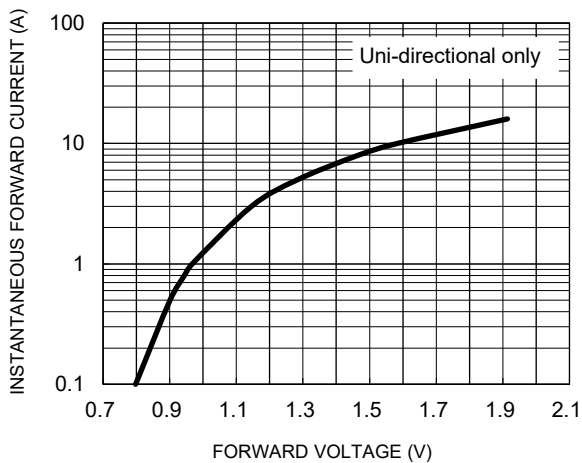
**Fig.1 Peak Pulse Power Derating Curve**



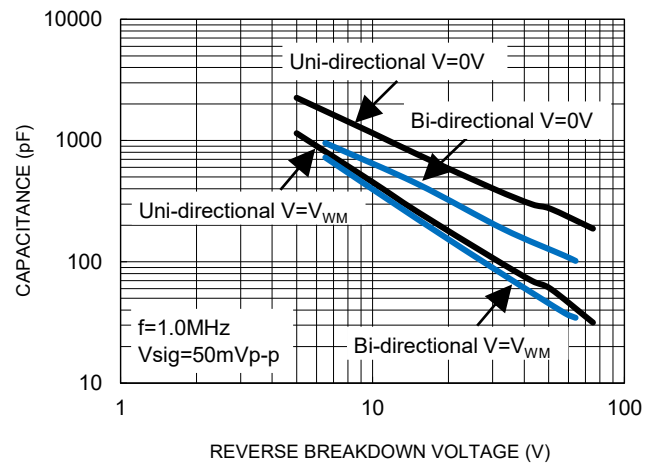
**Fig.2 Non-Repetitive Peak Pulse Power vs. Pulse Time**



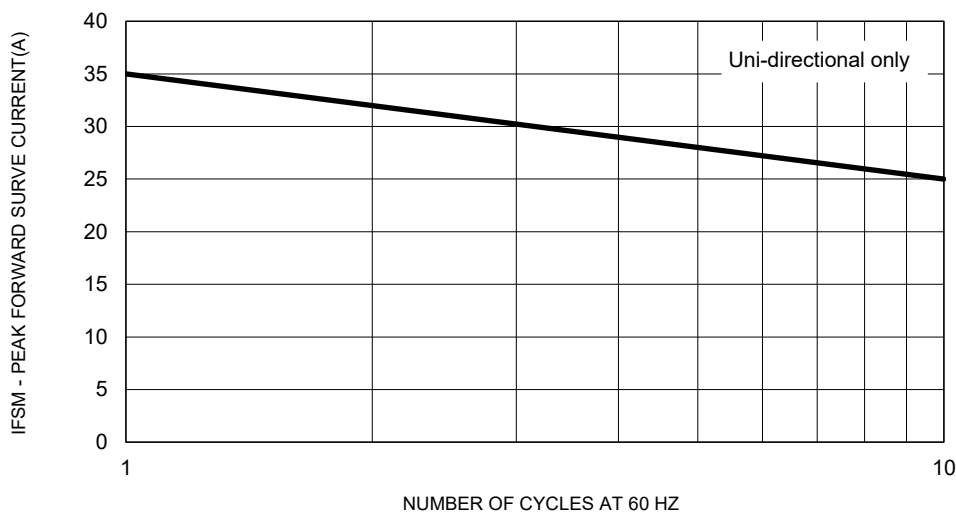
**Fig.3 Forward Voltage vs. Peak Forward Current**



**Fig.4 Typical Junction Capacitance**



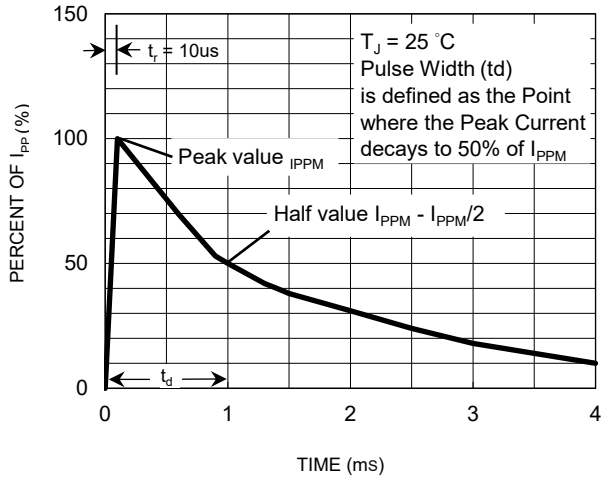
**Fig.5 Maximum Non-Repetitive Forward Surge Current**



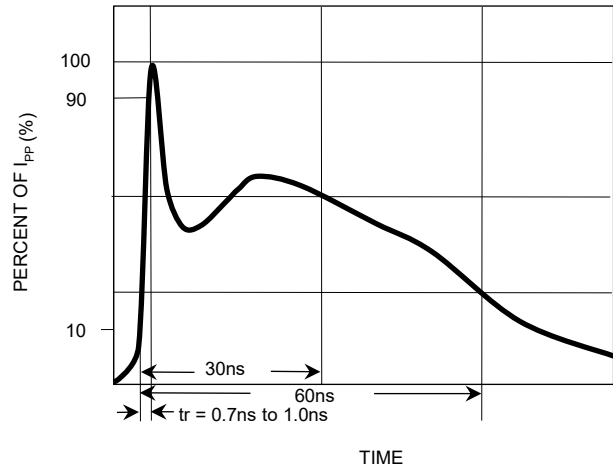
**CHARACTERISTICS CURVES**

( $T_A = 25^\circ\text{C}$  unless otherwise noted)

**Fig.6 10/1000 $\mu\text{s}$  pulse waveform**

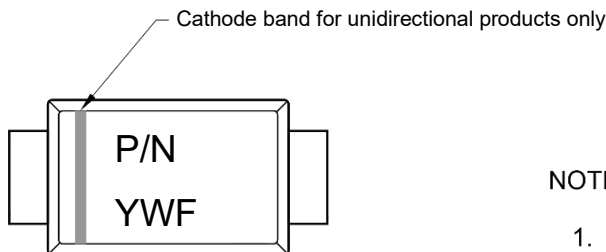
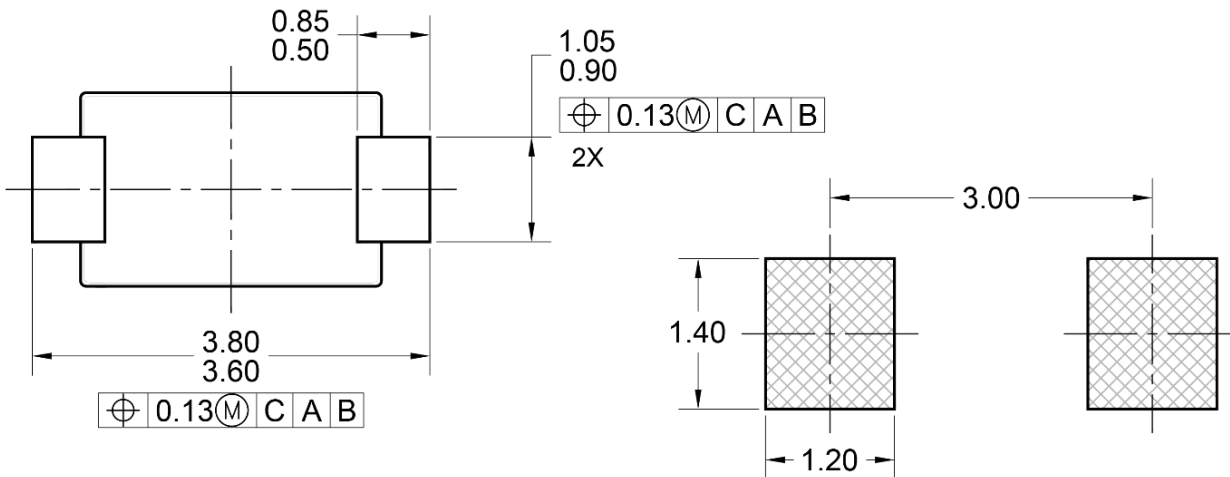
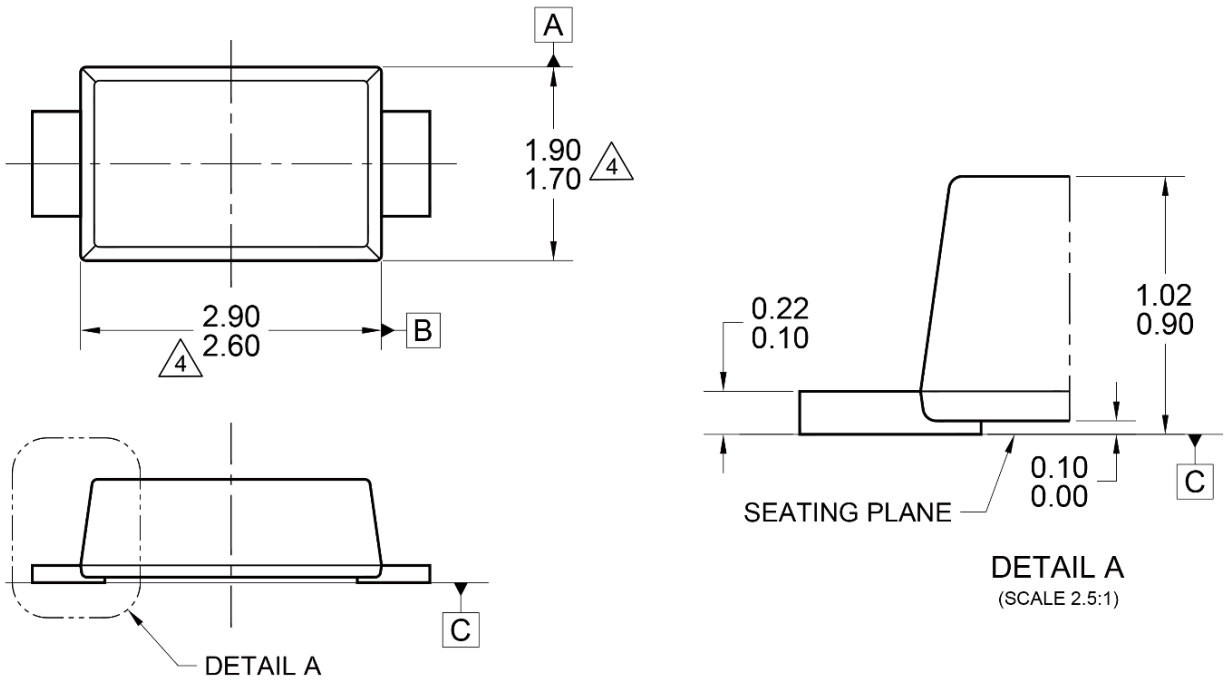


**Fig.7 ESD pulse waveform**



**PACKAGE OUTLINE DIMENSIONS**

**SOD-123W**



**MARKING DIAGRAM**

P/N = Device marking  
 YW = Date code  
 F = Factory code

**SUGGESTED PAD LAYOUT**

**NOTES: UNLESS OTHERWISE SPECIFIED**

1. ALL DIMENSIONS ARE IN MILLIMETERS.
2. DIMENSIONING AND TOLERANCING PER ASME Y14.5M-2009.
3. PACKAGE OUTLINE REFERENCE: JEDEC DO-219, VARIATION AB, ISSUE C.
4. MODDED PLASTIC BODY DIMENSIONS DO NOT INCLUDE MOLD FLASH.
5. DWG NO. REF: HQ2SD07-SOD123W-037 REV A.

## **Notice**

Specifications of the products displayed herein are subject to change without notice. TSC or anyone on its behalf assumes no responsibility or liability for any errors or inaccuracies.

Purchasers are solely responsible for the choice, selection, and use of TSC products and TSC assumes no liability for application assistance or the design of Purchasers' products.

Information contained herein is intended to provide a product description only. No license, express or implied, to any intellectual property rights is granted by this document. Except as provided in TSC's terms and conditions of sale for such products, TSC assumes no liability whatsoever, and disclaims any express or implied warranty, relating to sale and/or use of TSC products including liability or warranties relating to fitness for a particular purpose, merchantability, or infringement of any patent, copyright, or other intellectual property right.

The products shown herein are not designed for use in medical, life-saving, or life-sustaining applications. Customers using or selling these products for use in such applications do so at their own risk and agree to fully indemnify TSC for any damages resulting from such improper use or sale.