

# SGT MOSFET Development Status

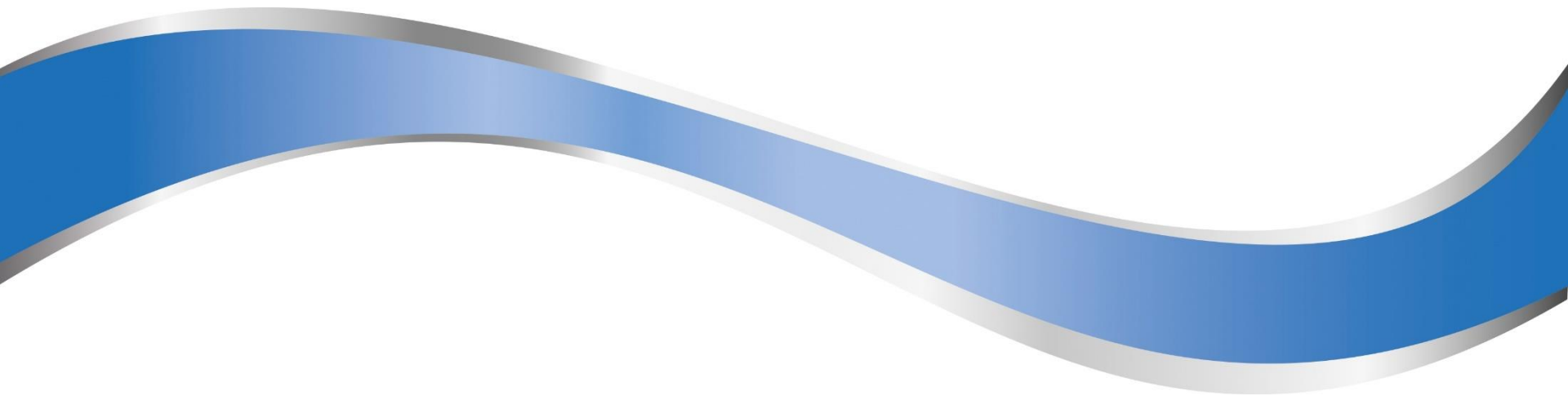

# 全球銷售據點 & 重點客戶合格供應商



# 台半車用MOSFET高端製程能力

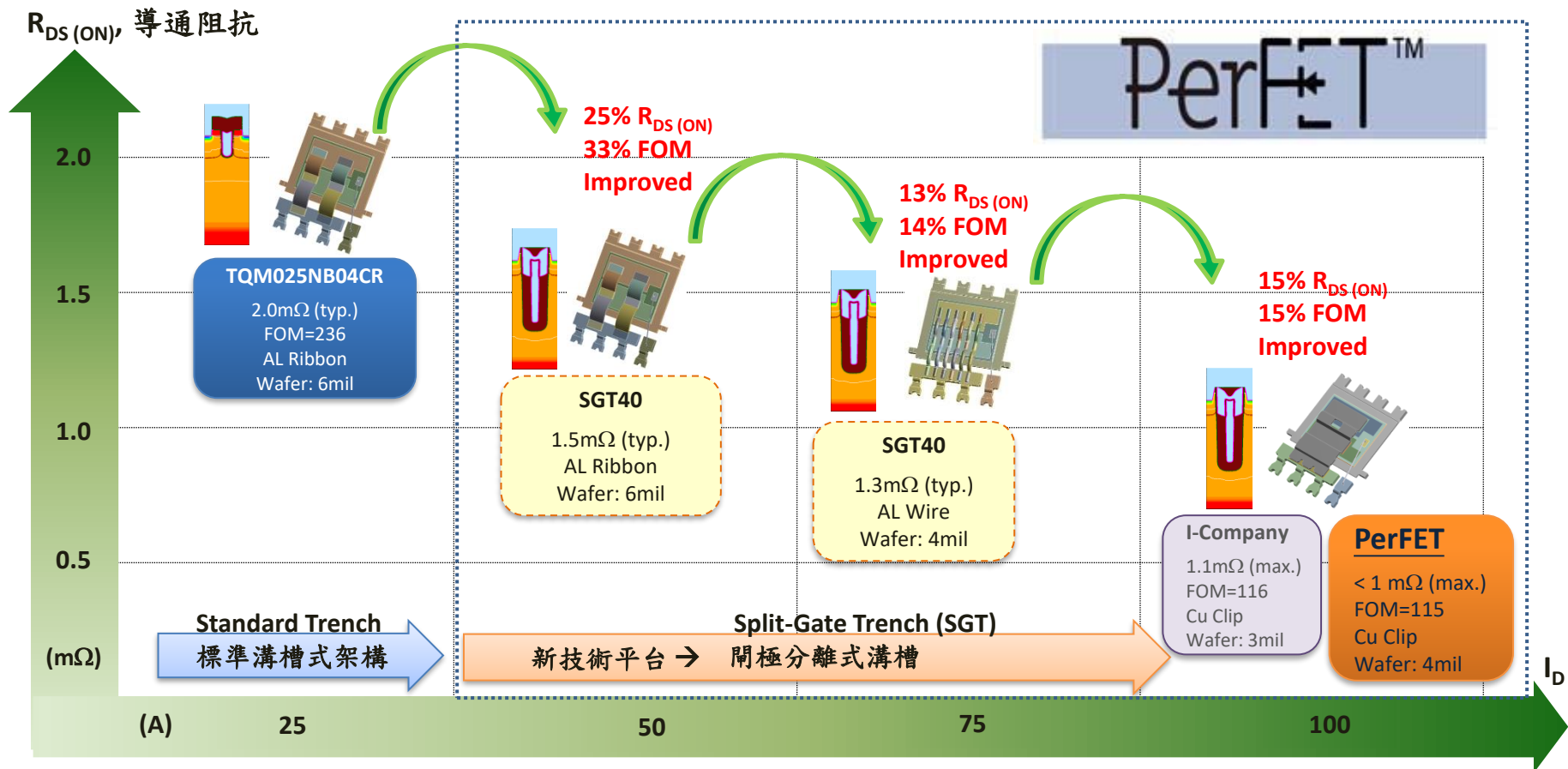

FOM (Figure-of-Merit): MOSFET 產品性能指數

# 台半車用MOSFET專案時程

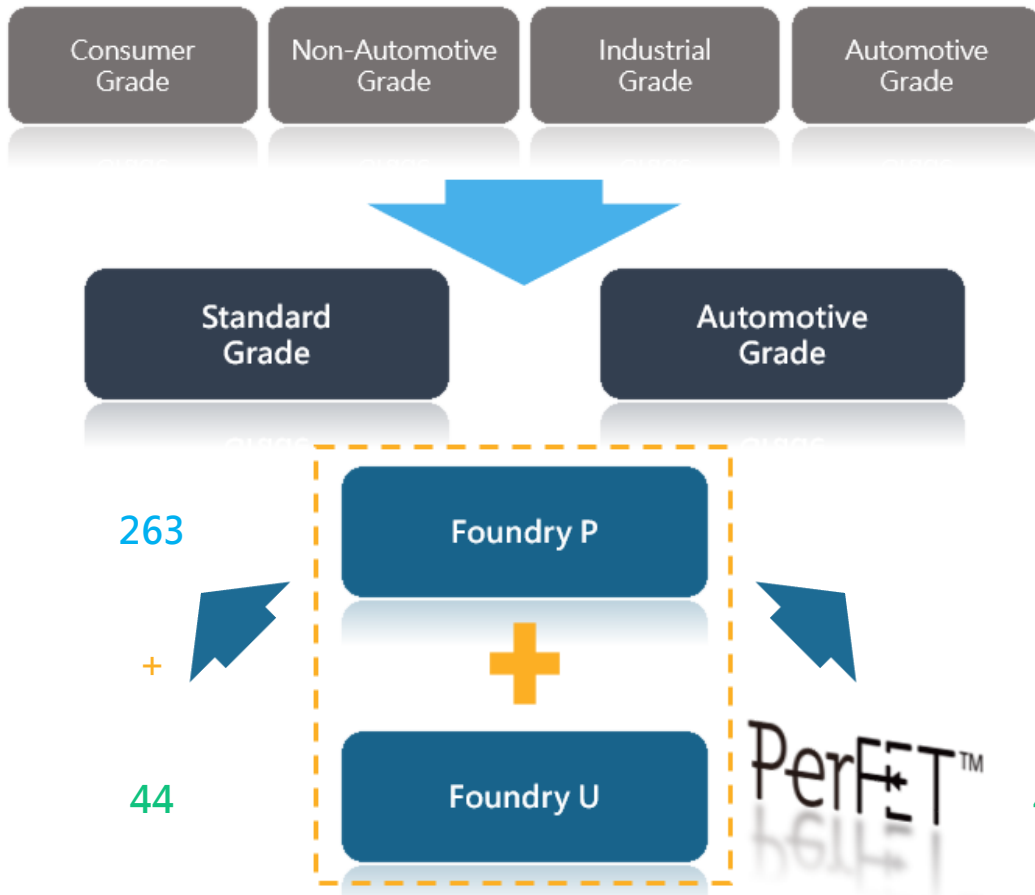

## 產品優勢

- 自主設計
- (雙) 晶圓廠 代工協作
- 產品規格提升
- 品質 + 價值 + 競爭力

# 台半車用MOSFET專案時程

- SL: Standard Level
- LL: Logic Level

○ Standard Grade Items    ○ Automotive Grade Items

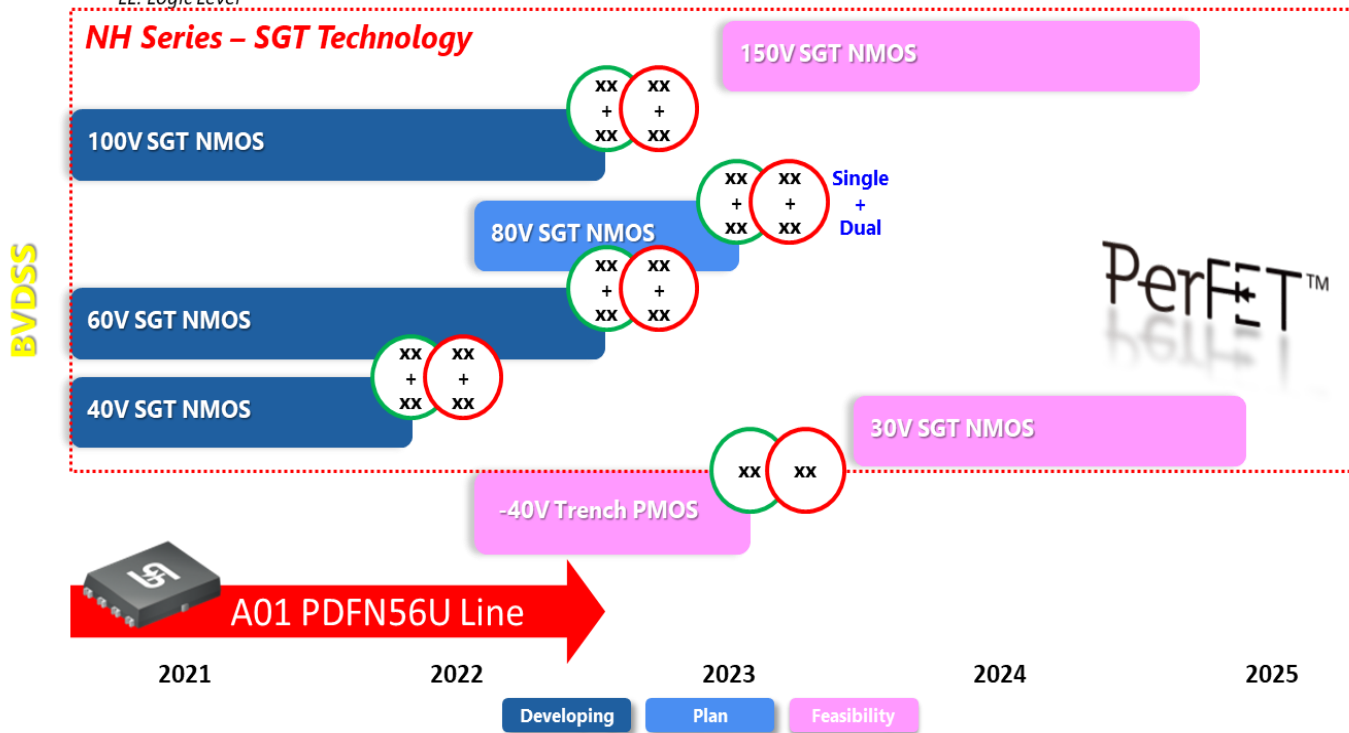

# MOSFET 於車用系統的應用



雨刷控制

電子控制單元

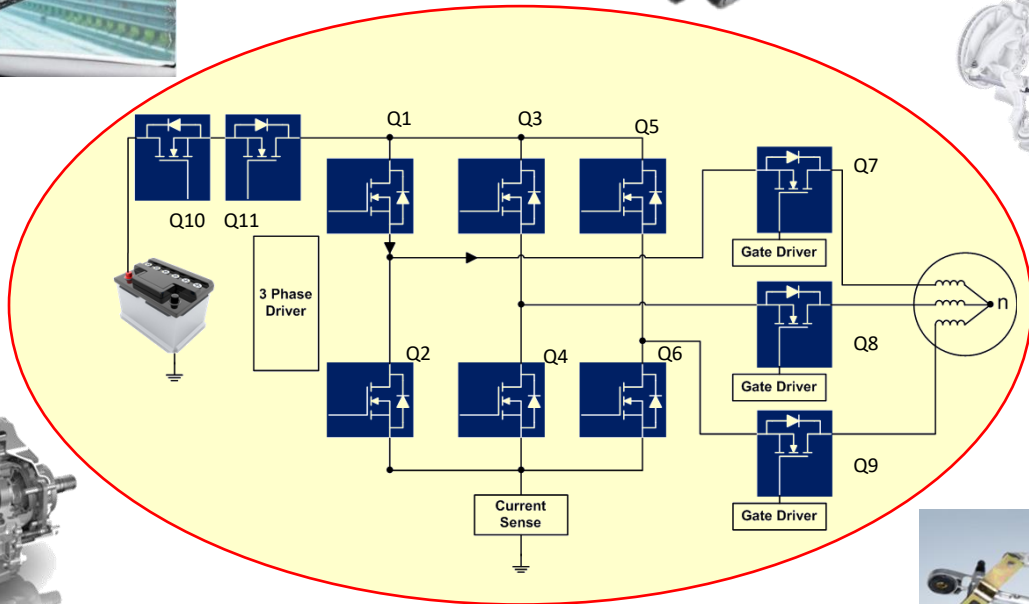

電子動力轉向系統

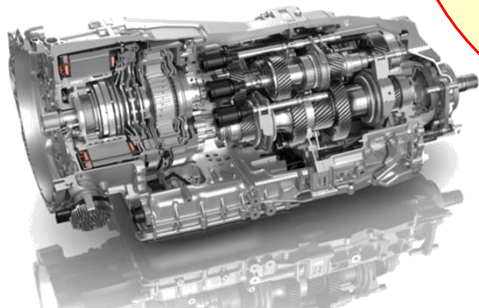

離合器傳輸控制



車窗升降馬達控制器

## MOSFET基本應用需求:

- $V_{DS}$  電壓: 40V 及 60V
- 低阻抗  $R_{DS(ON)}$ , 低工耗, 高效率
- 貼鉚封裝, ex. DFN 5x6, DFN 3x3, ...



# MOSFET 於車用系統的應用 (cont.)

## 動力總程系統 (Powertrain)

40V MOSFET, N-Channel  
3.3mΩ, 7mΩ, 11mΩ

## 暖通空調系統 (HVAC)

40V, N-Channel, SDT/SGT  
1.8mΩ, 2.5mΩ, 3.3mΩ

## 車用照明 (Lighting)

60V, N-Channel, SL  
11mΩ, 13mΩ

## 離合器傳輸控制 (Clutch)

40V, N-Channel, SDT/SGT  
1.8mΩ, 2.5mΩ, 3.3mΩ

## 車身控制模組 (BCM)

40V MOSFET, N-Channel  
3.3mΩ, 7mΩ, 11mΩ

車窗、雨刷、  
座位、車廂、  
天窗、  
後照鏡...

## 儀錶板 (Dashboard)

40V, N-Channel, 11mΩ

## 電子動力轉向系統 (EPS)

40V, N-Channel, SGT, LL/SL  
0.95mΩ, 1.1mΩ

## 電磁閥 (Solenoid Valve)

60V, N-Channel, SDT/SGT  
11mΩ, 15mΩ

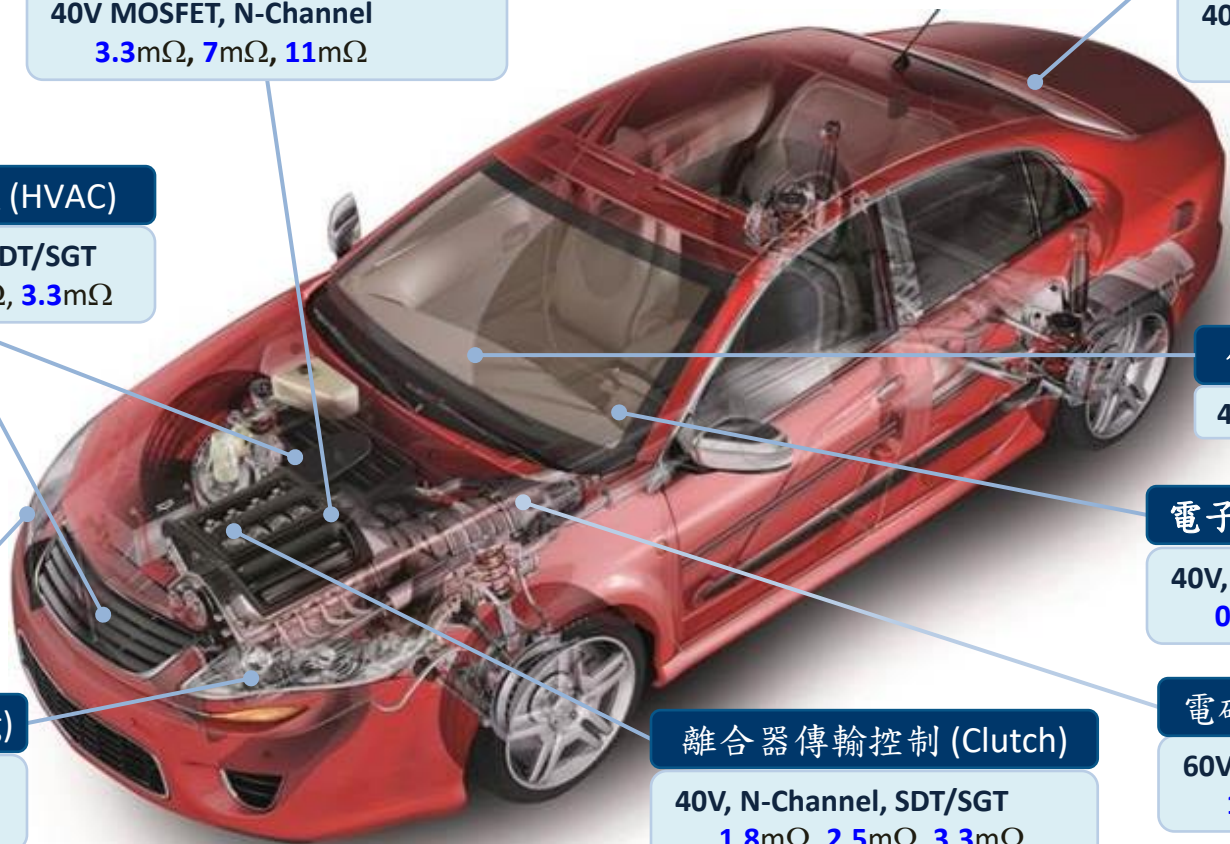



# TSC, Your Reliable Partner

**Taiwan Semiconductor Co., Ltd.**

## **Headquarter**

Address: 11F, No. 25, Sec. 3, Beishin Rd., Shindian Dist., New Taipei City, Taiwan

Telephone: +886-2-8913-1788

E-Mail: [marketing@mail.ts.com.tw](mailto:marketing@mail.ts.com.tw)

Website: [www.taiwansemi.com](http://www.taiwansemi.com)